

DIN 912 M12

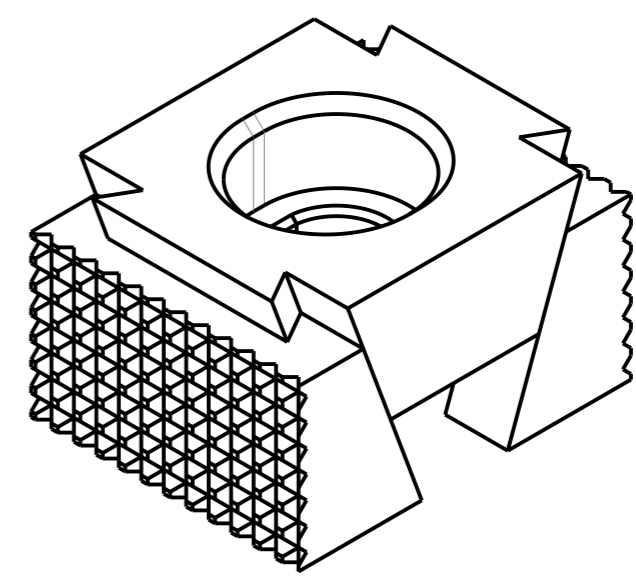
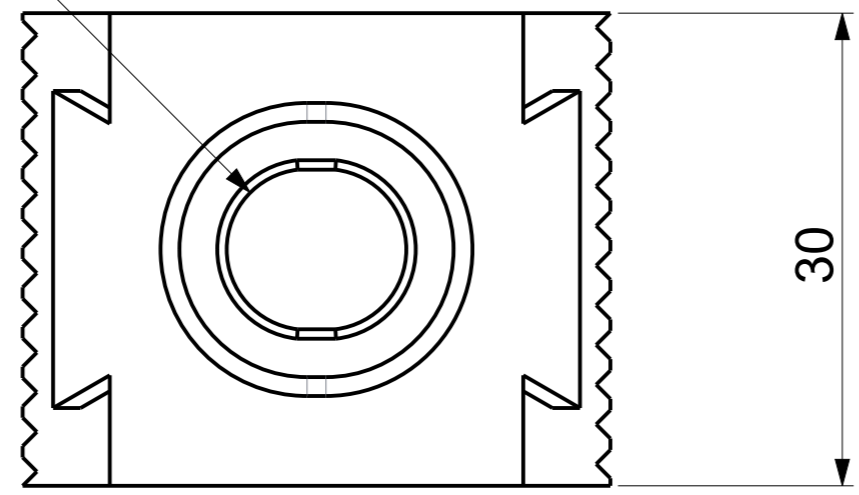

**WEDGE CLAMP WITH SERRATED JAW**

Art.No. FG/WH/WEDCL/00SJ2NP001

Model No. KD-SJ-2

Tightening Torque. 65 Nm

Clamping Force. 30 kN