

| | | |
|--|----------|---|
| | 0.02/300 | |
| | 0.02/300 | Z |
| | 0.02/300 | Y |

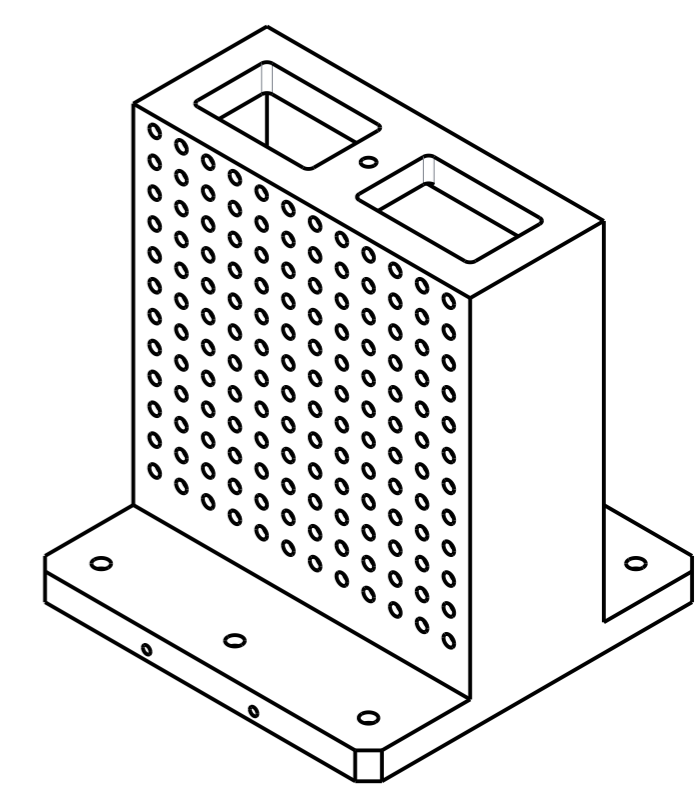
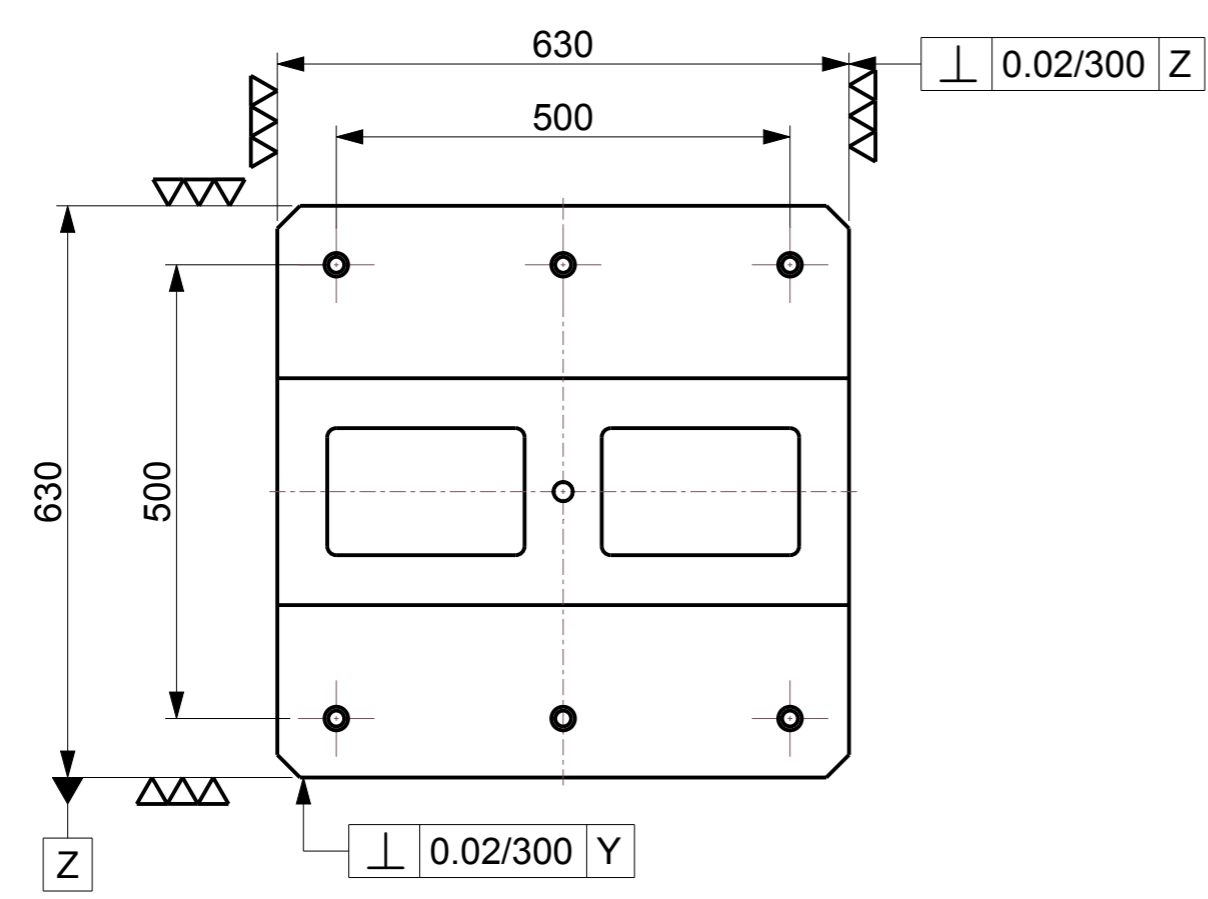
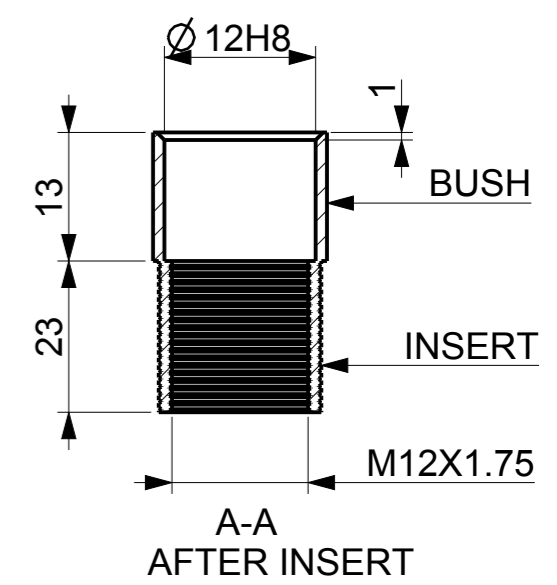
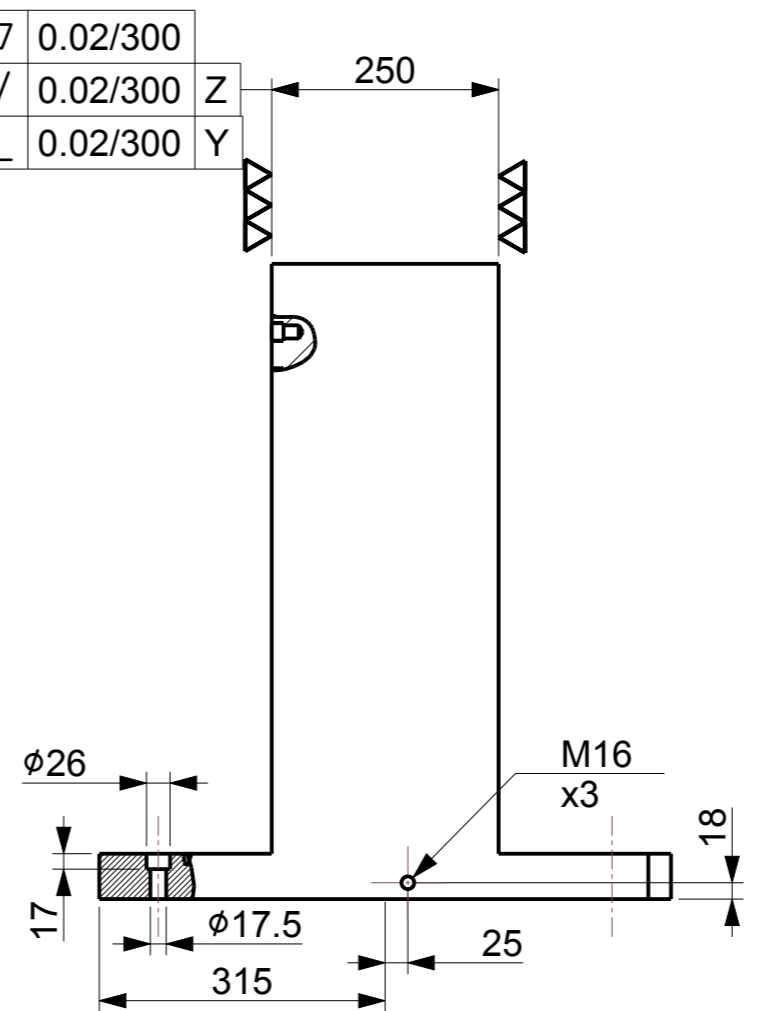

DOUBLE SIDED CLAMPING COLUMN - GRID HOLE
 Art.No. FG/WH/TOMB/RCGRDNP005
 Model No. TSG/RT/250630-12