

SECTION B-B  
SCALE 0,170

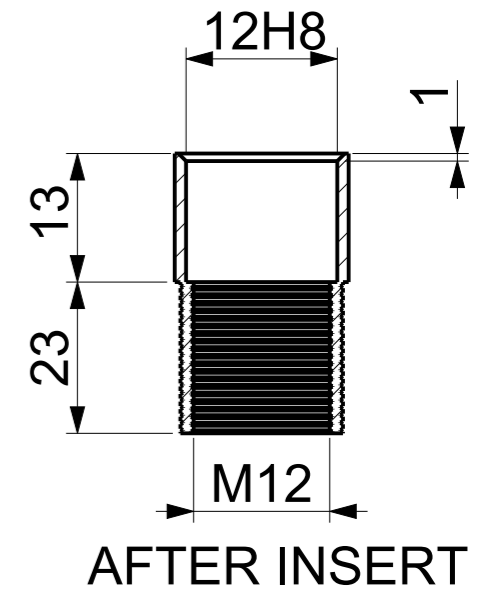
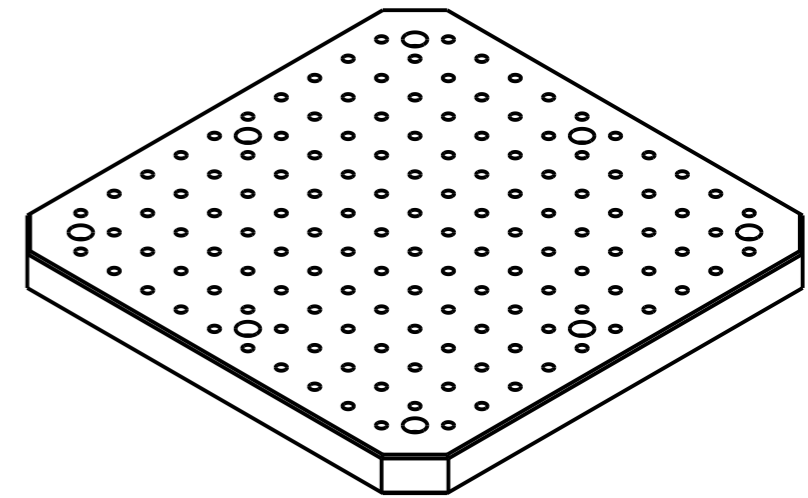
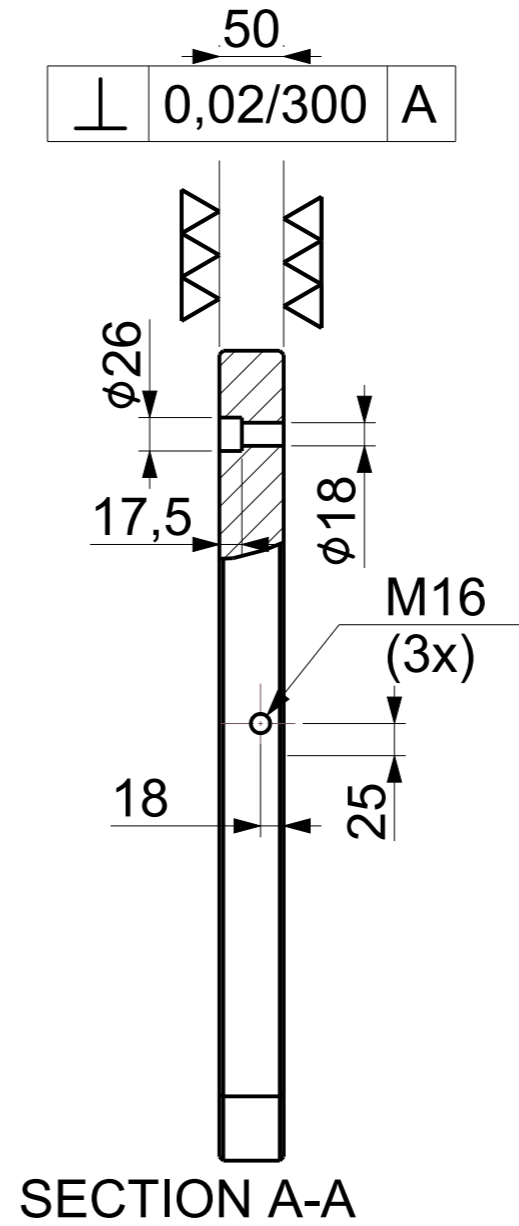

**SQUARE BASE PLATE GRID HOLE**

Art. No. FG/WH/BASPL/SQGRDNP003

Model. No. BPG/SQ/630-12