

SECTION B-B

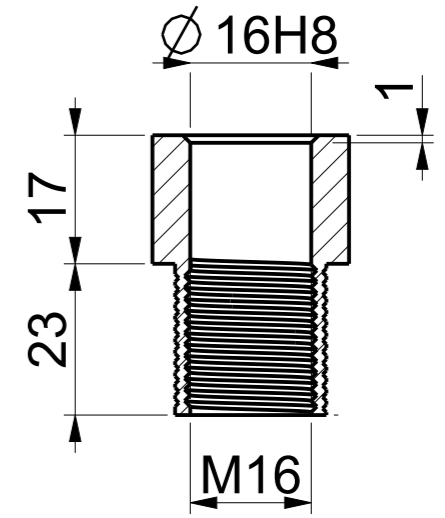

AFTER INSERT

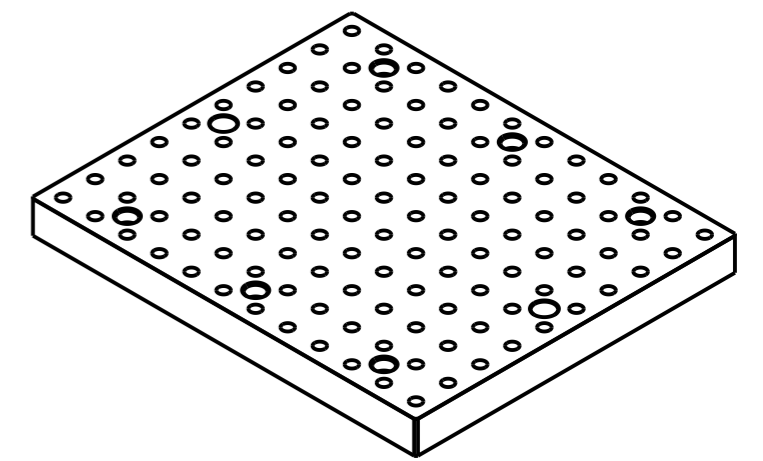
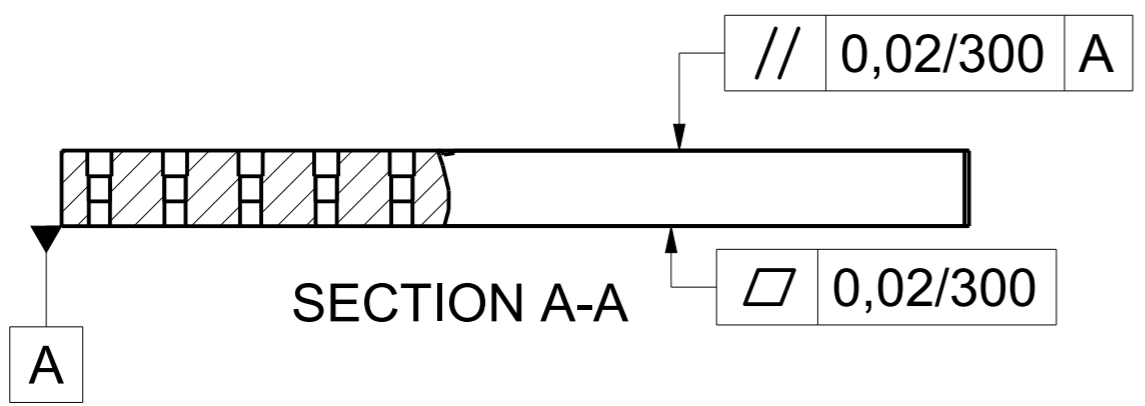

RECTANGULAR BASE PLATE GRID HOLE

Art. No. FG/WH/BASPL/RCG16NP002

Model. No. BPG/RT/500600-16