

# WORK HOLDING SOLUTIONS

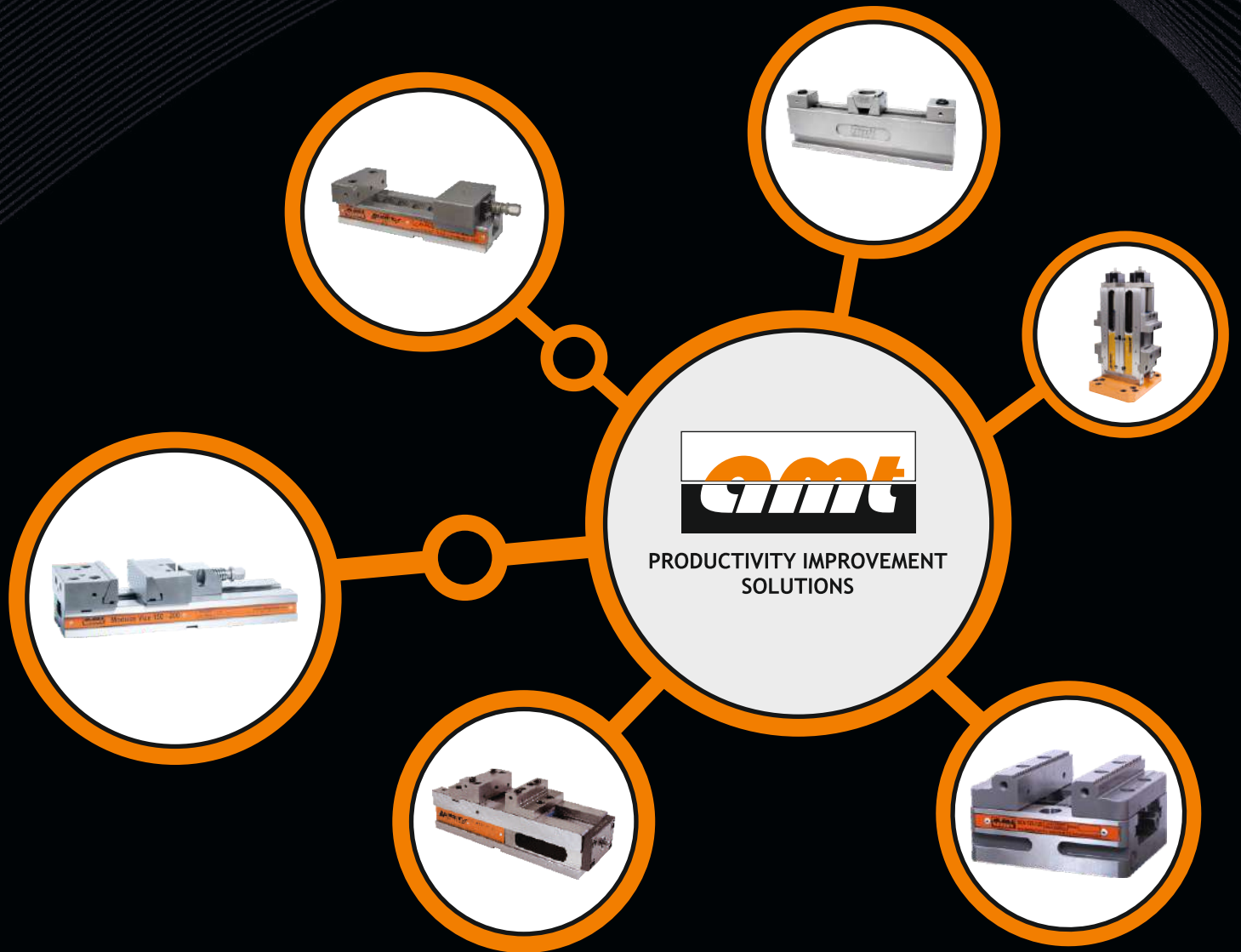

*Quality Creates Trust...*

# INDEX

<b>NO.</b>	<b>SUBJECTS</b>	<b>PAGE NO.</b>
01	PRECISION MACHINE VISE 125/160	01
02	COMBINATION VISE 125/160	04
03	MODULAR VISE-MV 100/ 200/300 /400	07
04	MECHANICAL - NC 4	09
05	MECHANICAL - LC 125	11
06	GRIPP MECHANICAL - TITAN SC 125	14
07	GRIPP MECHANICAL - T-REX	19
08	GRIPP MECHANICAL - CENTRO 125	21
09	ALL LITE 68 K/M	24
10	TELECENTRIC 70 K/M	27
11	SELF CENTRIC VISE-SCV 125/225	29
12	BACK TO BACK LC 125 /TITAN SC 125	32
13	WEDGE CLAMP	34
14	RAIL VISE	36
15	WORK HOLDING-BASE PLATE / TOMBSTONE	40

## Scope of Application

- VMC machine - for efficient precision machining
- Horizontal installation - great variability and flexibility

## Product Features

- Alloy steel body & case hardened
- Excellent ease of operation guarantees optimal handling for every application
- Fast adjustment for clamping range presetting
- Operation with the ring wrench supplied
- Reproducible clamping forces are achieved using a torque wrench
- Integrated scrapers ensure functional reliability and minimise cleaning
- Fixing on the machine table by means of mounting holes in the vise base. Additional holes can be made in the soft middle section of the vise base
- Optional centre jaw allows two or more work pieces to be clamped



M8 thread for workpiece stop

M10 thread for mounting Jaws

M8 thread for mounting Jaws

Hardened, ground and polished guideway



## Application Image

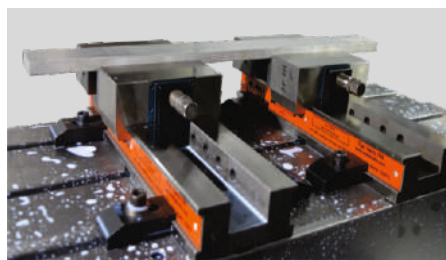
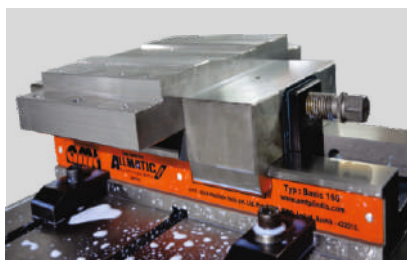

## Technical Data

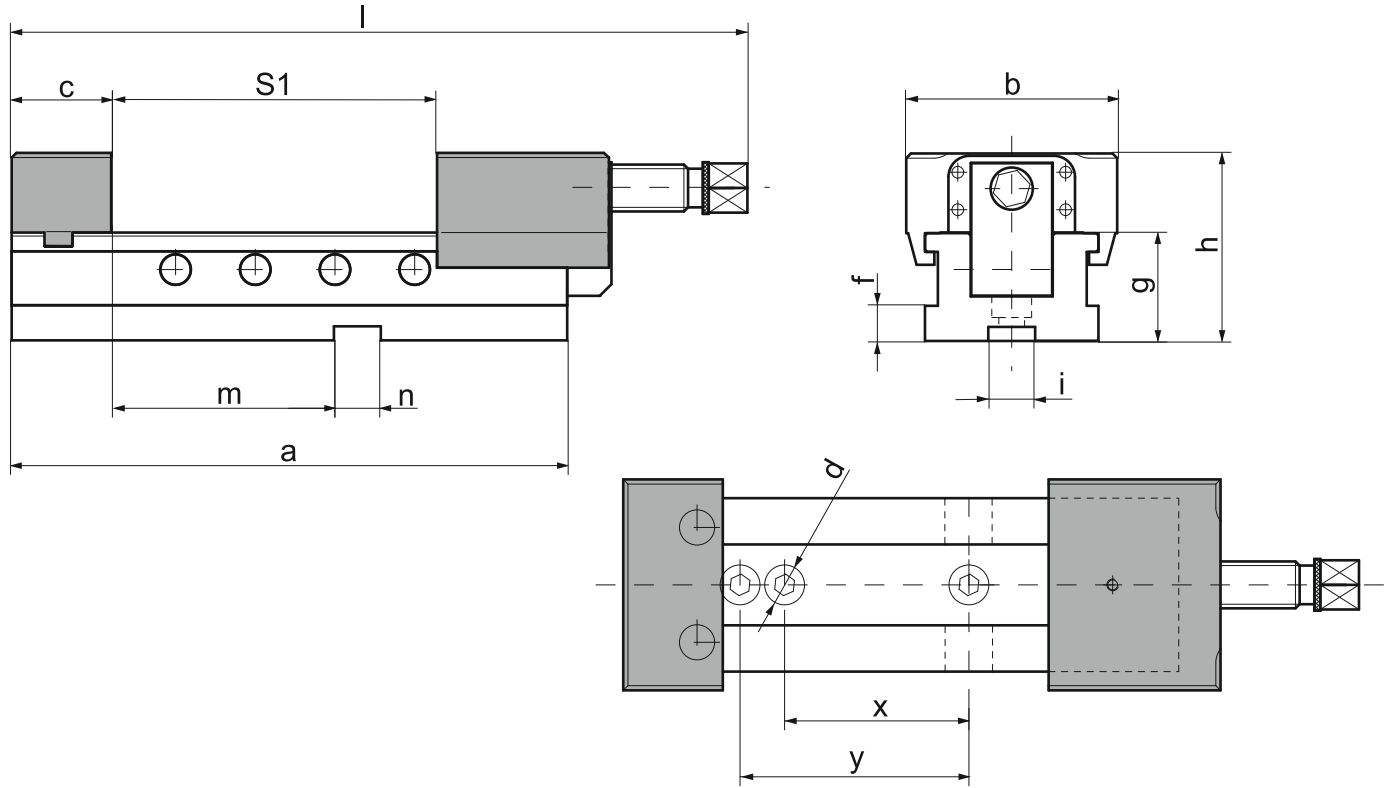

Variant		Basic 125	Basic 160
Dimensions/ Tolerances in mm	a	310	405
	b	124	160
	c	50	66
	d	13	13
	f	15	15
	g	48	56
	h	87.5	105.5
	i	20	20
	l	426	483
	m	120	128
	n	20	20
	x	100	100
y	125	125	

Variant	Basic 125	Basic 160
Clamping range $S1$ in mm	1-208	1-283
Torque in Nm	85	120
Max. clamping force in KN	35	50
Weight in kg	13.5	26

### Scope Of Supply

- Basic Vise With Clamping Jaws - 1 No.
- Universal Jaw Assembly - 1 Set
- Work Piece Stopper - 1No.
- Click Parallel 3thk x ht 35mm -1 Set
- Side Clamp - 4 Nos.
- Combination Spanner-19mm - 1 No.
- T-type Allen Key-6mm - 1 No.
- Tenon 20x16 - 2 No.

## Universal Jaws (Set)



Universal combination jaws with

- Step
- Serrations
- Integrated gripper row

\* In Standard scope of supply

## Intermediate Jaws

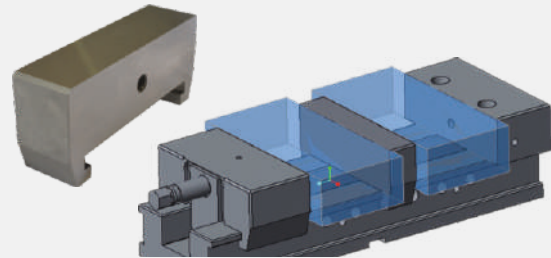

- For clamping two or more work pieces
- Installation between fixed and movable jaws of the vise

\* On Request

## Click Parallel (Set)

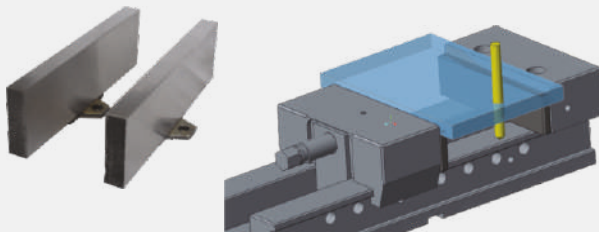

	125	160
Sizes in mm	10X25	10X25
Sizes in mm	10X35	10X44
Sizes in mm	3X35	3X44

\* In Standard scope of supply

## Prismatic Jaws

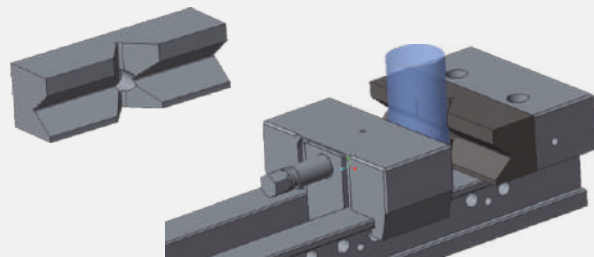

- Jaws for clamping round parts  
Vertically and Horizontally

	125	160
Horizontal	dia 12 - 28	dia 15 - 40
Vertical	dia 18 - 55	dia 22 - 65

\* On Request

## Workpiece Stop

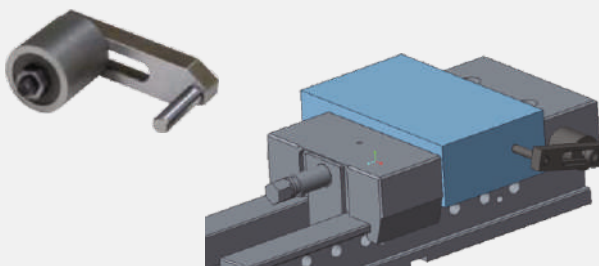

- Can be mounted on either side of the vise in the designated positions
- Position of the third workpiece axis can be preset and clamped
- Can be pre-mounted with various fixed dimensions.

\* In Standard scope of supply

## Soft Jaw (set)

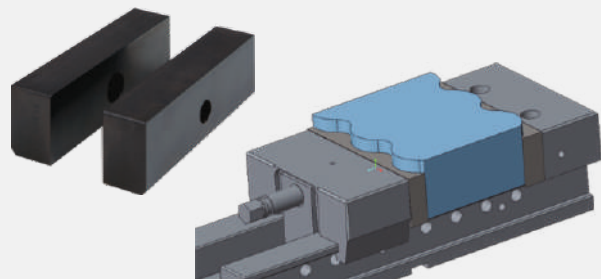

- For production of special jaws by the customer for Profile or irregular Shape workpiece
- Case-hardened steel 20MnCr5 material

\* On Request

# COMBINATION VISE 125/160

## Scope Of Application

- Conventional and CNC controlled heavy duty milling machines

## Product Features

- Alloy steel body and case hardened
- Excellent ease of operation guarantees optimal handling for every application
- Fast adjustment for clamping range presetting
- Operation with the ring wrench supplied
- Reproducible clamping forces are achieved using a torque wrench
- Integrated scrapers ensure functional reliability and minimise cleaning
- Allow perfect clamping even of big workplace which need the heaviest machining using machine table as surface
- Manufactured under rigid quality control, hence can maintain accuracy under most severe operating conditions
- Space saving design & easy to handle

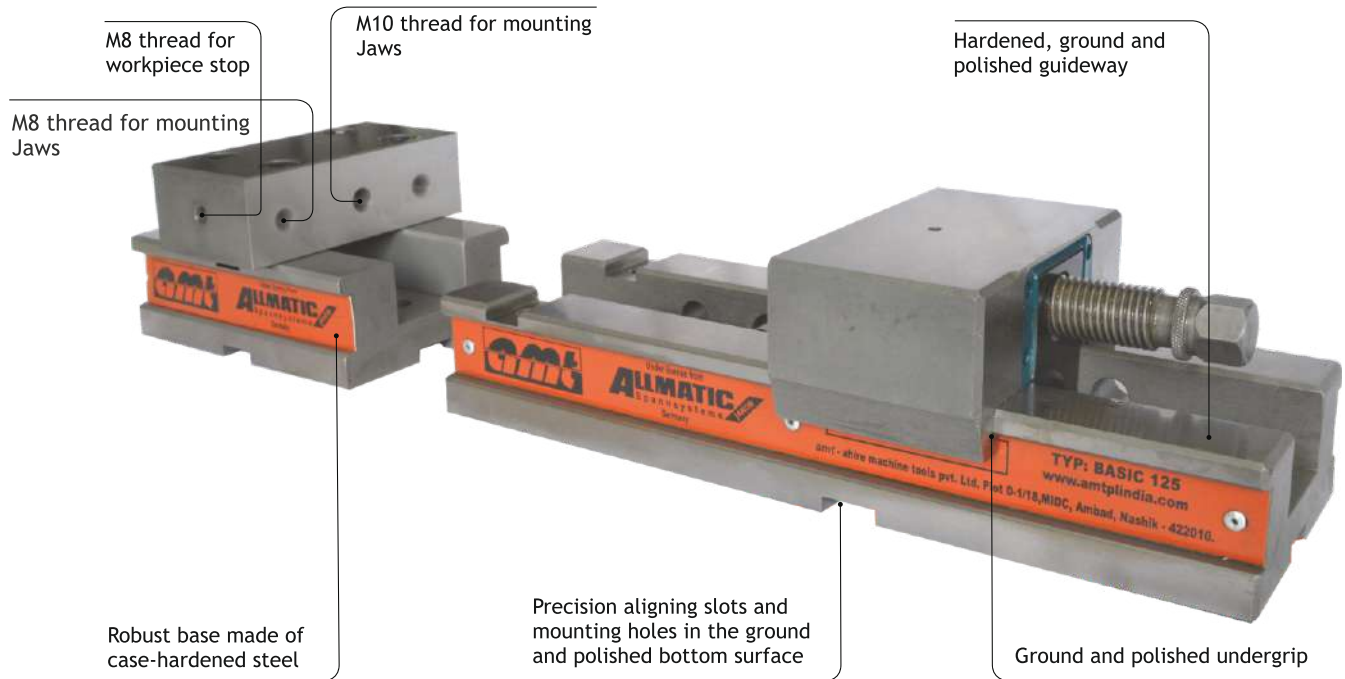

## Application Image

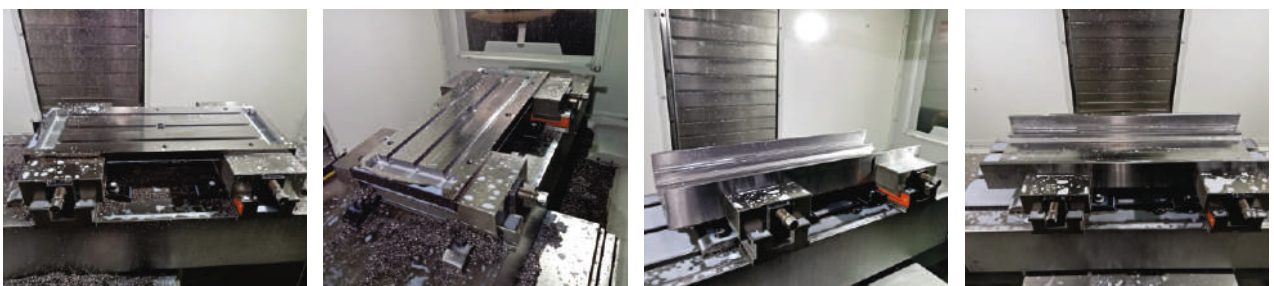

## Technical Data

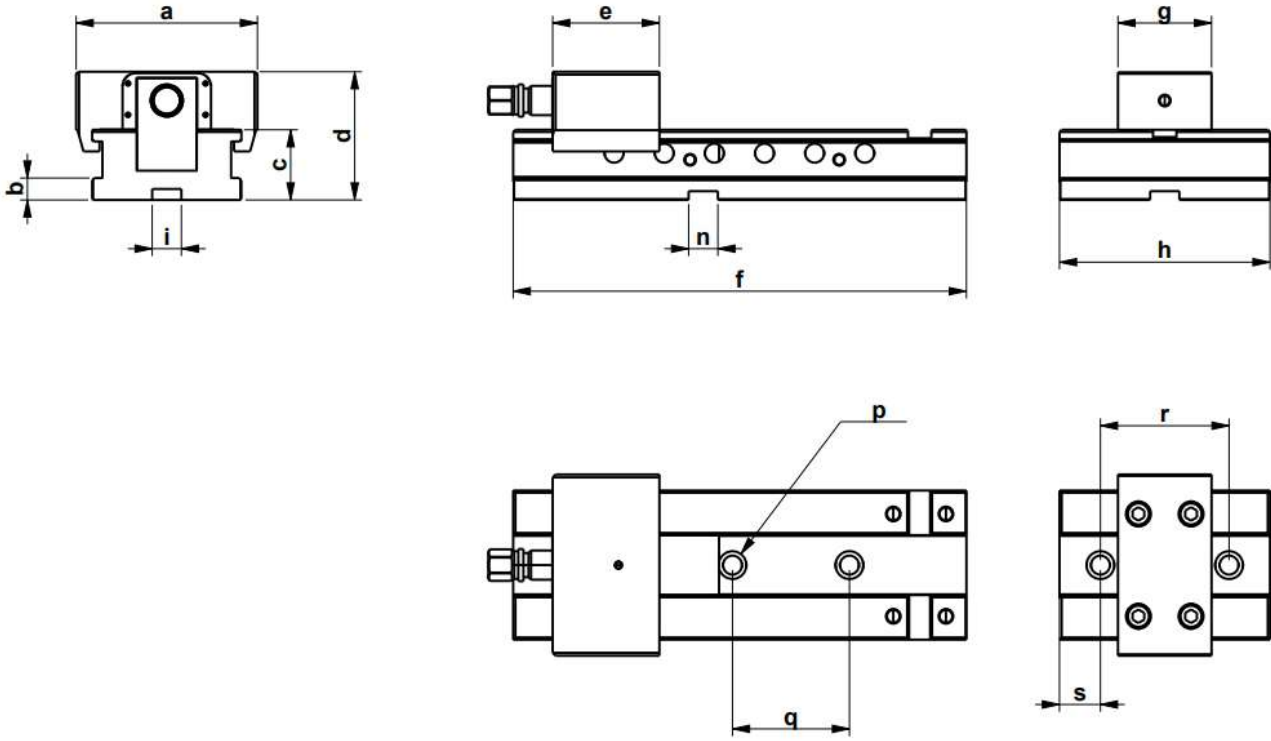

Variant	Combi 125	Combi 160	
Dimensions in mm	a	125	160
	b	15	15
	c	48	56
	d	87.5	105.5
	e	35	50
	f	310	405
	g	64	84
	h	150	200
	i	20	20
	n	20	20
	p	13	13
	q	80	80
	r	88	100
s	40	63	

Variant	Combi 125	Combi 160
Torque in Nm	85	120
Max. clamping force in KN	35	50
Weight in kg (2 Module)	48	56
Minimum clamping range in mm	87.5	105.5

### Scope of Supply

Description	1 Module	2 Module
Fix Jaw Unit 125/160	1 NO.	2 NO.
Extension body 125/160	1 NO.	2 NO.
Side clamp 125/160	8 NO.	16 NO.
Combination spanner-19mm	1 NO.	2 NO.
T-type allen key-6mm	1 NO.	2 NO.
Tenon 20X16 basic 125/160	4 NO.	8 NO.
Work piece stopper-basic	1 NO.	2 NO.
Universal Jaw 125/160	1 Set	2 Set

## COMBINATION VISE EXAMPLES

Medium sized workpieces, Blocks & Plates clamped on vise sections

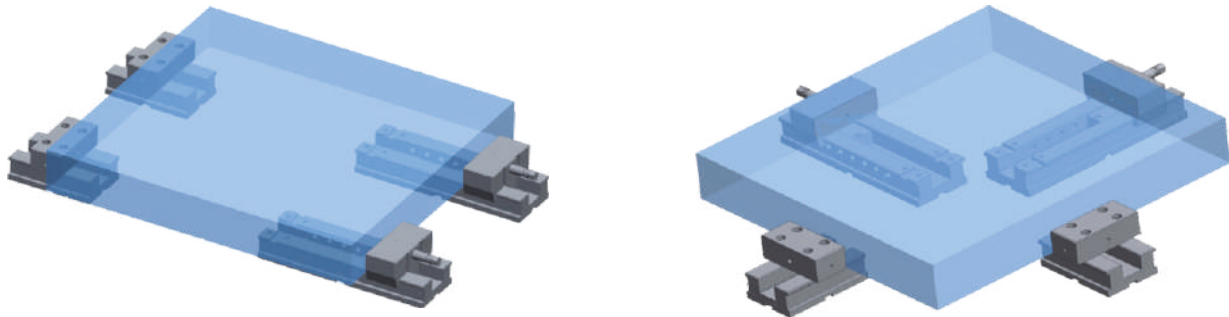

Long workpiece clamped on vise section using extension of fix jaw.

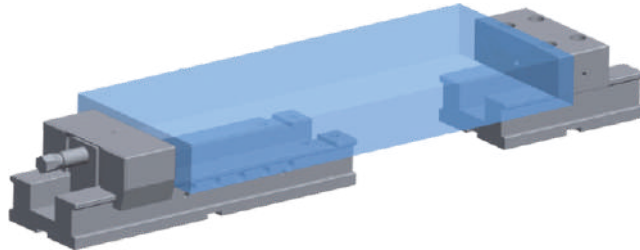

Two workpieces with different sizes clamped on vise using one fix jaw & two movable jaw extensions.

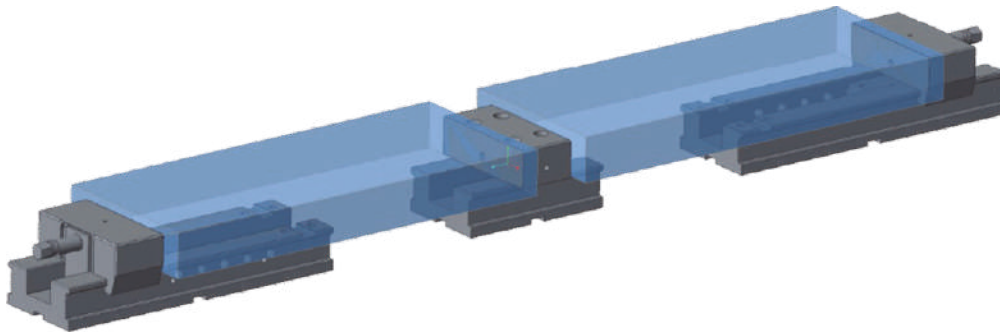

Used as regular vise for holding smaller components.

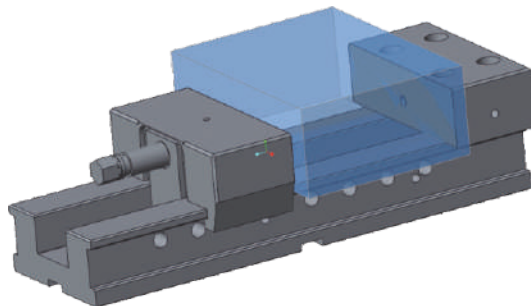



# MODULAR VISE - MV 100 / 200 / 300 / 400

## Scope of Application

- VMC machine - for efficient precision machining
- Horizontal installation - great variability and flexibility



## Product Features

- Alloy steel body and Case-hardened at 60 HRC with Rigid construction and exclusion of **Vibrations**
- Parallelism of body is within 0.02 mm. vice with pull-down jaws.
- Since the workpiece is clamped by pulling down, floating up is prevented in spite of the **Powerful clamping force**
- Reproducible clamping forces are achieved using a torque wrench
- 4 extra tapped holes over the jaws for special stack type jaw application

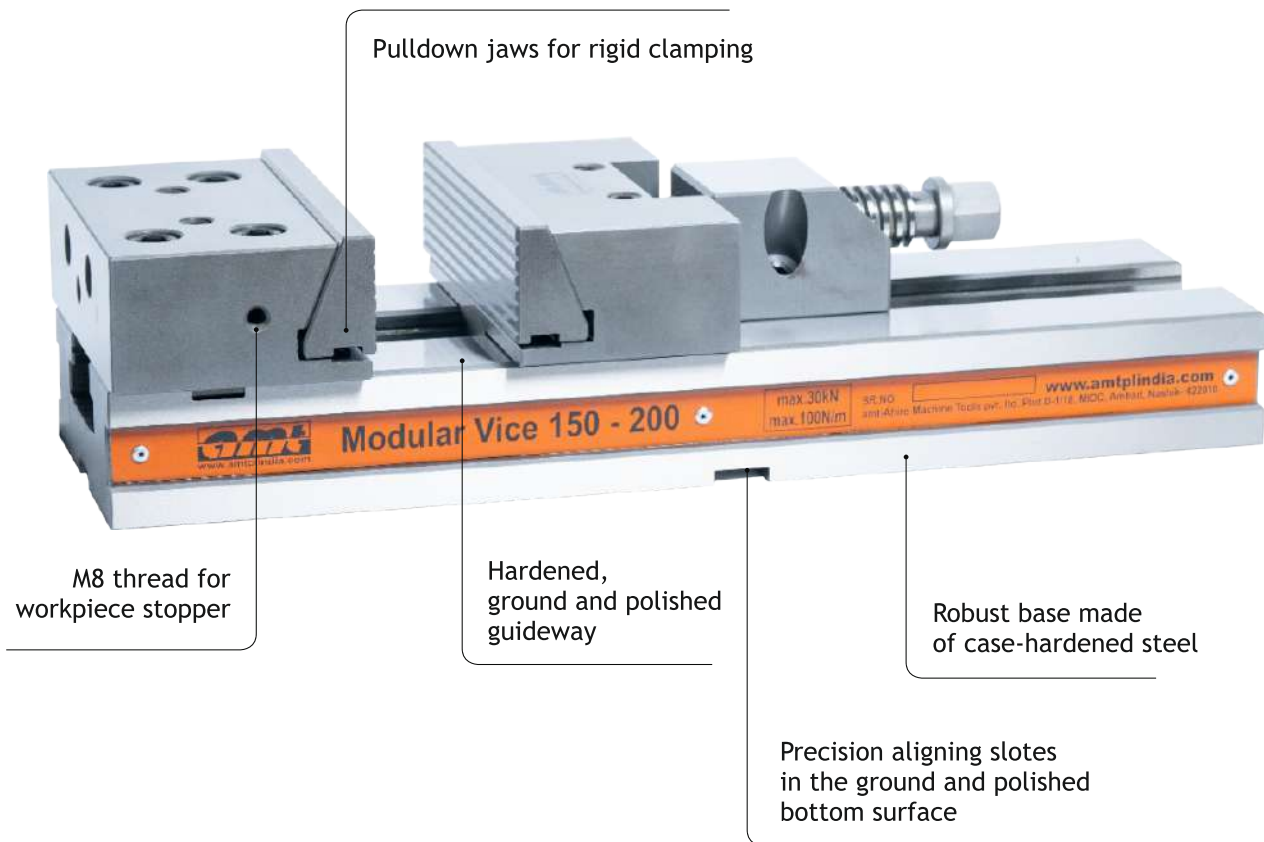

## Application Image



## Technical Data

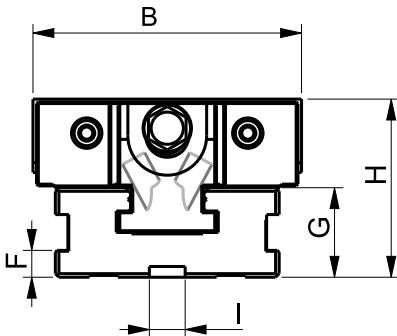
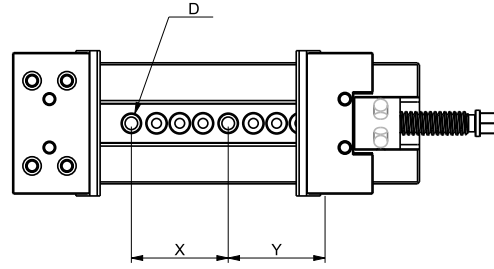
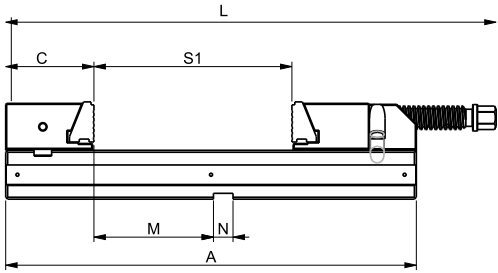

## ACCESSORIES

### Prismatic Jaw

Jaws for clamping round parts,  
Horizontal diameter : 12-28 mm,  
Vertical diameter : 18-55 mm

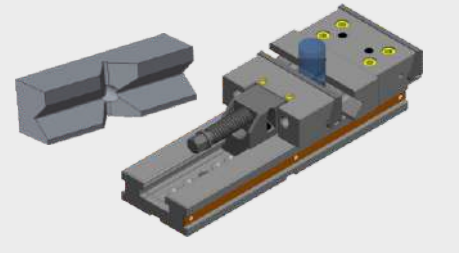

**Note :** Prismatic Jaw only applicable for MV150-200, MV150-300

Variant	MV 100-100	MV 150-200	MV 150-300	MV 200-400	
Dimensions in mm	a	270	420	520	695
	b	100	150	150	200
	c	67	90	90	114
	d	N/A	21	21	26
	f	11	15	15	21
	g	35	50	50	70
	h	65	100	100	133
	i	20	20	20	20
	l	306	500	600	775
	m	63	122	122	121
	n	20	20	20	20
	x	N/A	100	100	100
	y	N/A	100	100	100
s1	105	200	300	400	

### Scope Of Supply

- Vise with Clamping Jaws- 1 No.
- Work Piece Stopper- 1 No.
- Side Clamp- 4 No.
- Combination Spanner/ L-Spanner (MV 200/300) - 1 No.
- T-type Allen Key -1 No.
- Tenon 20x16-2 No.

Variant	MV 100-100	MV 150-200	MV 150-300	MV 200-400
Dimensions (mm)	306 x100 x 65	500X150X100	600X150X100	775 X 200 X 133
Clamping Range (mm)	105	200	300	400
Maximum Clamping force (kN)	20	30	30	40
Maximum Torque (Nm)	30	100	100	-
Weight (Kg)	6.5	34	38	70

N/A - Not Applicable

## Scope Of Application

- Ideal for use on 3-axis machining centres
- Easy handling
- Max. 40 kN clamping force per one rotation with hand crank

## Product Features

- Max. clamping force 40 kN
- Constant, reproducible clamping force with mechanical power-assist
- Proven maintenance-free and encapsulated high-pressure spindle, thus minimized cleaning requirements
- Basic body made of GGG-60
- Guideway inductively hardened and ground
- Reversible jaws: for min. / max. chuck capacities
- Alloy steel body and case hardened

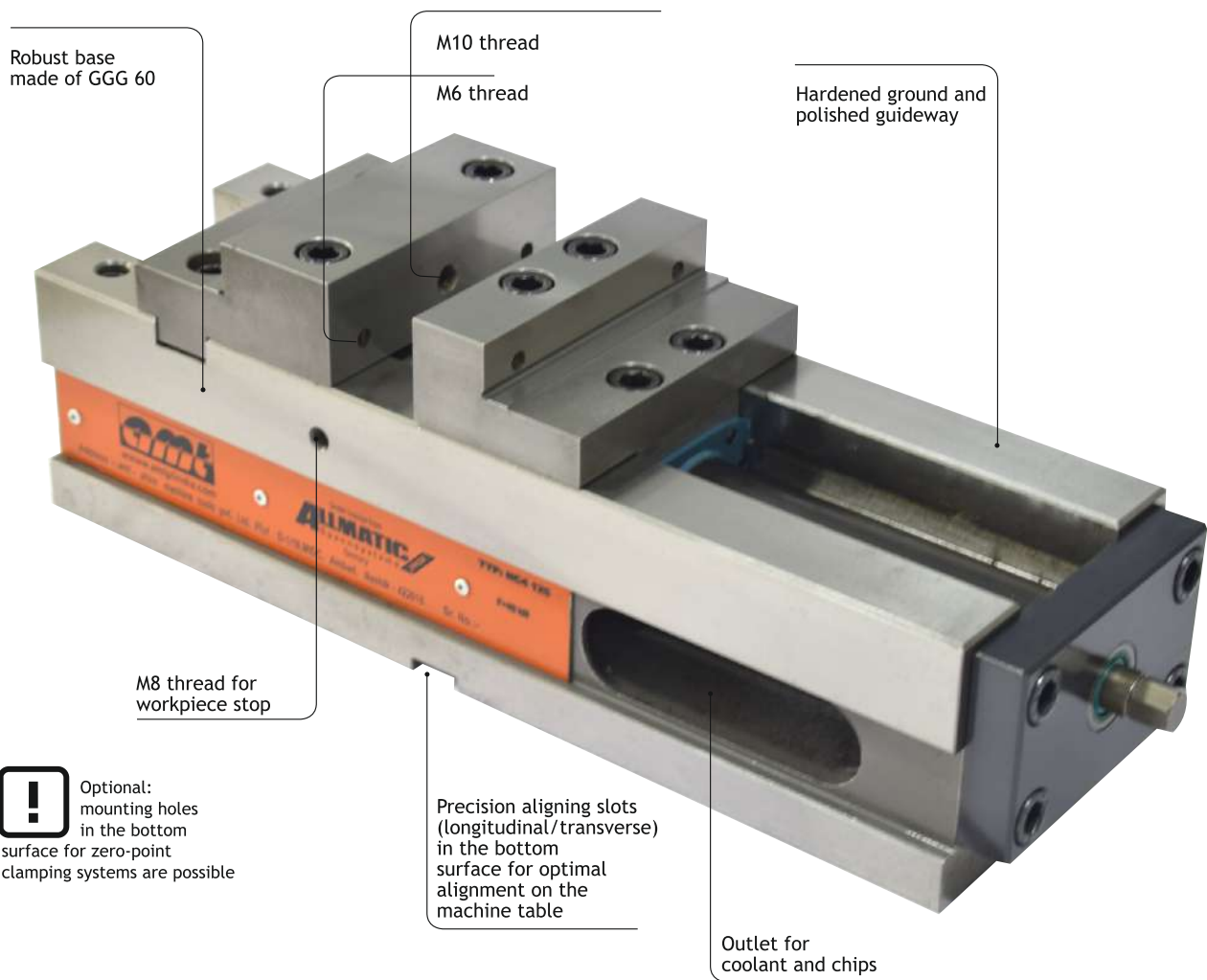

**!** Optional: mounting holes in the bottom surface for zero-point clamping systems are possible

## Technical Data

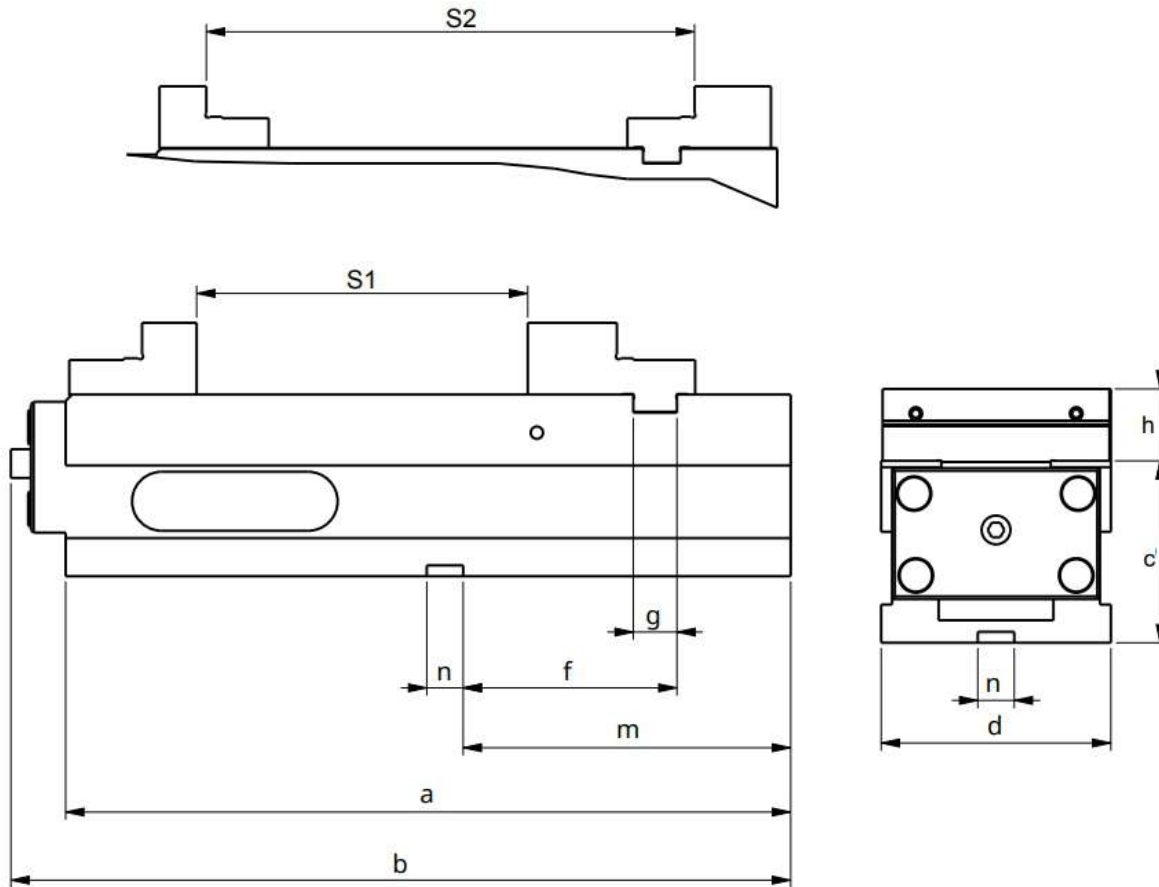

Variant	NC 4	
Dimensions in mm	a	398
	b	441
	c	100
	d	126
	f	118
	g	24
	h	39.5
	m	180
	n	20
	x	36
y	127	

Variant	NC 4	
Clamping range S1 in mm	0-182	
Clamping range S2 in mm	131-313	
Max. clamping force in kN	40	
Weight in kg	36	

### Scope Of Supply

- Nc 4 Vise With Step Jaws - 1 No.
- Universal Jaw Assembly - 1 Set
- Crank Handle - 1 No
- Work Piece Stopper - 1 Set
- Side Clamp - 4 Nos
- Tenon 20x16 - 2 Nos

# MECHANICAL - LC 125

## Scope Of Application

- Horizontal installation - suitable for vertical CNC controlled milling machines

## Product Features

- Alloy steel body & case hardened
- Extreme accuracy for your machining
- Clamping force can be preset in 4 increments.  
At most, 2 revolutions are required to reach the max. clamping force
- Preselectable and reproducible clamping forces enable the workpiece position to be repeated within a tolerance of less than 0.01 mm



Robust base made of GGG 60

M10 thread

M6 thread

Hardened ground and polished guideway

Clamping force presetting

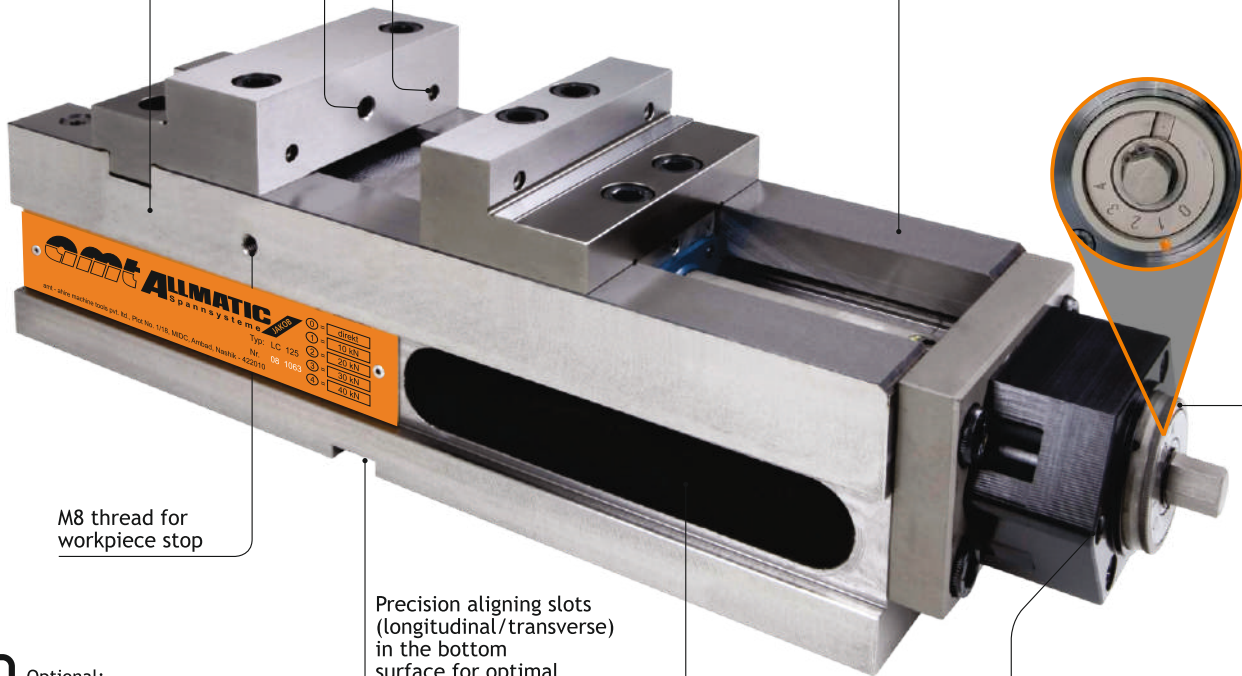

M8 thread for workpiece stop

Precision aligning slots (longitudinal/transverse) in the bottom surface for optimal alignment on the machine table

Outlet for coolant and chips

Connecting thread for angular drive

**!** Optional: mounting holes in the bottom surface for zero-point clamping systems are possible

## Application Image

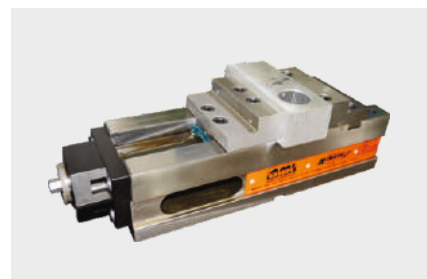
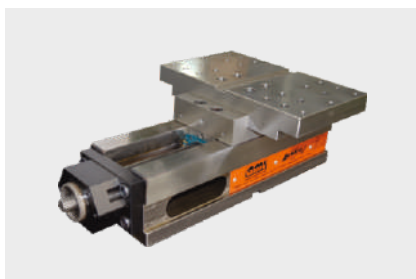

## Technical Data

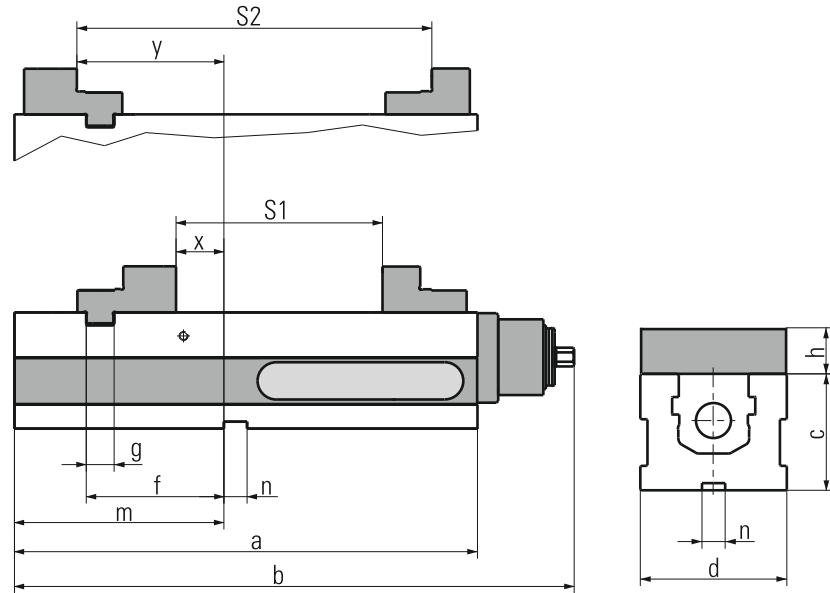

### Spindle cross-section

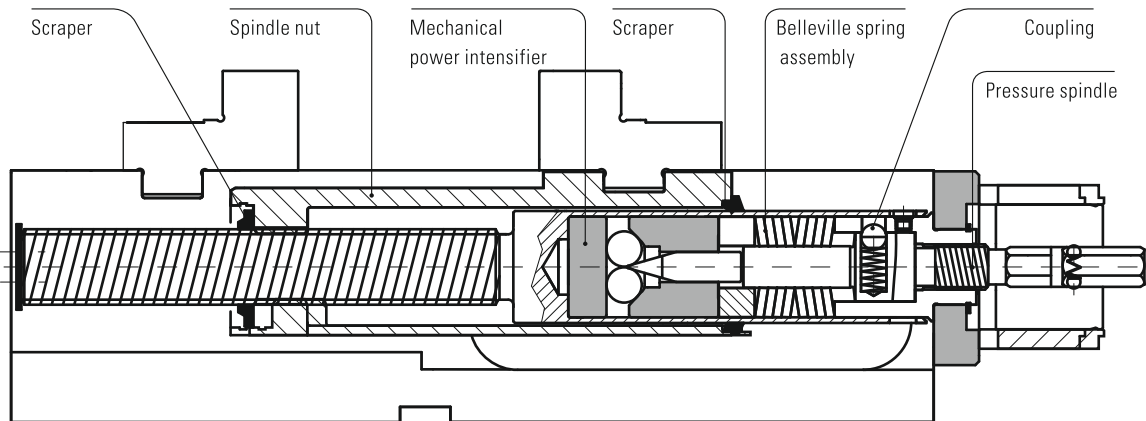

Variant	LC 125	
Dimensions in mm	a	398
	b	483
	c	100
	d	126
	f	118
	g	24
	h	39.5
	m	180
	n	20
	y	127

Variant	LC 125	
Clamping range S1 in mm	0-182	
Clamping range S2 in mm	131-313	
Max. torque in Nm	30	
Max. clamping force in kN	40	
Weight in kg	36	

### Scope Of Supply

- LC 125 Vise With Step Jaws -1set
- Crank Handle -1 No.
- Work Piece Stopper -1 Set
- Side Clamp - 4 Nos.
- Tenon 20x16 - 2 Nos.
- Universal Jaw Assembly Basic 125 1 Set

## Universal Jaws

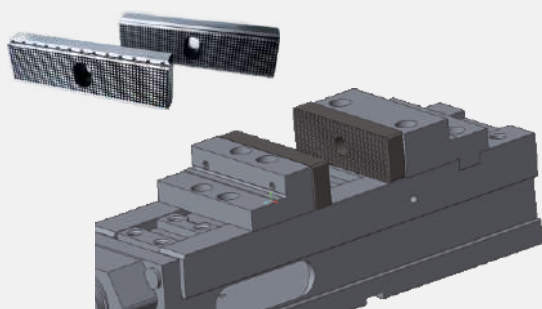

- Standard jaws with serration
  - To increase the specific contact pressure per unit area
- \* In Standard scope of supply

## Master Jaw Adapters

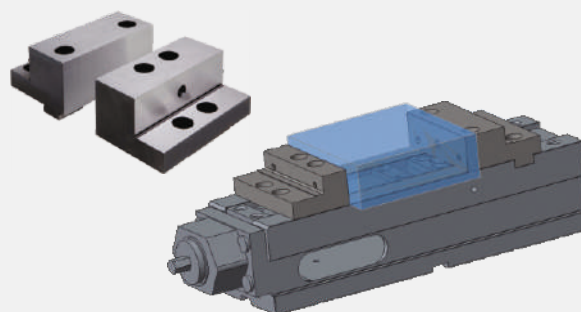

- High side of jaw harden
  - Ground clamping surfaces
  - Additional thread on the step side for mounting HD jaws
  - Click system on the high side
- \* On Request

## Workpiece Stop

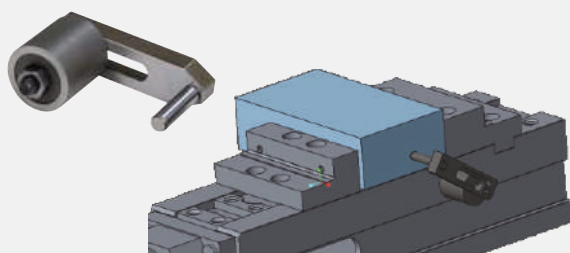

- Can be mounted on either side of the vise in the designated positions
  - Position of the third workpiece axis can be preset and clamped
  - Workpiece stop can be swivelled away once the workpiece has been clamped
- \* In Standard scope of supply

## Soft Jaws (Set)

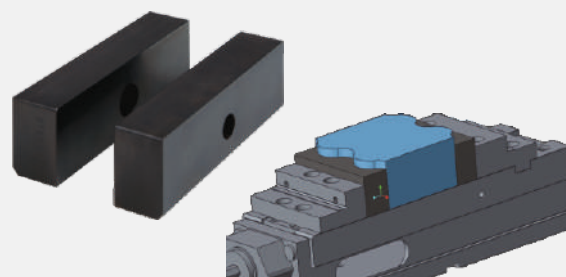

- Jaws can be case-hardened
  - For production of special jaws by the customer for Profiled & irregular shape components
- \* On Request

## Prismatic Jaws

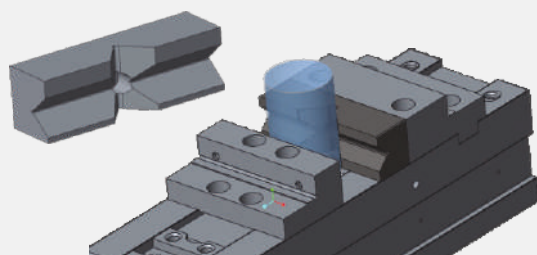

- Jaws for clamping round parts, horizontal dia. 12-28mm, vertical dia. 18-55 mm

\* On Request

## Click Parallel (Set)

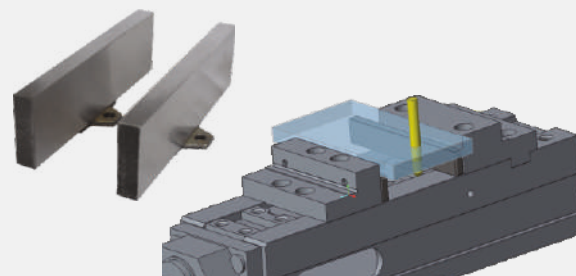

	LC125
Sizes in mm	10X25
Sizes in mm	10X35
Sizes in mm	3X35

\* On Request

## Scope Of Application

- The classical, universal clamp, for vertical 3 axis machining centres
- Conventional clamping and gripp clamping possible
- Clamping of raw parts, burn and saw cuts by penetrating hardened and interchangeable gripp elements into the workpiece

## Customer advantages:

- Free of charge introduction to gripp technology in comparison to conventional clamping (LC)
- **Existing** step jaw systems of product series LC / TC / Titan **can be used**
- First and second clamping stations without retrofitting the step jaws
- Clamping of raw parts such as burn & saw cuts (materials up to approx. 1000N/mm<sup>2</sup>) through screwable clamping applications (first clamping station)

- Parallel clamping to machined workpieces with the step jaws (2. clamping station)
- Upgrade to full clamping function with optional clamping jaws

## Product Features

- Alloy steel body & case hardened
- With grounded jaws, the TITAN SC 125 has the precision which is necessary for machining workpieces
- Fully enclosed gripp spindle for clamping and forming raw material
- The high-pressure spindle allows you to, with a mechanical force amplifier (using the torque wrench), to work and clamp to a table
- Stable GGG60 body, grounded top and bottom
- Double-sided M8 thread for workpiece stoppage
- Precise tracks in the grounded surface of the soles for optimum alignment on the machining table
- Click-quick-change system for attaching jaws and click parallels

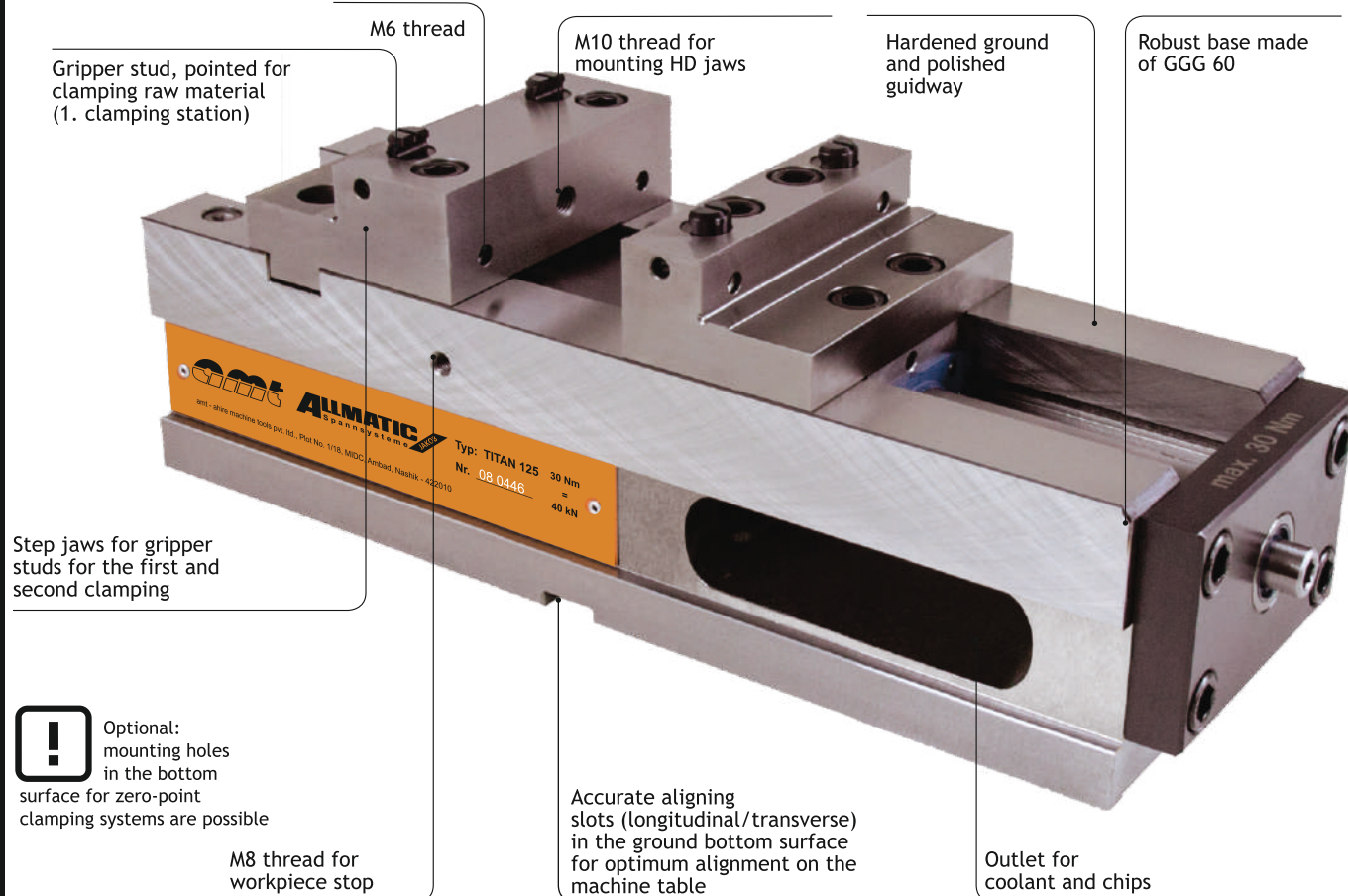

## Technical Data

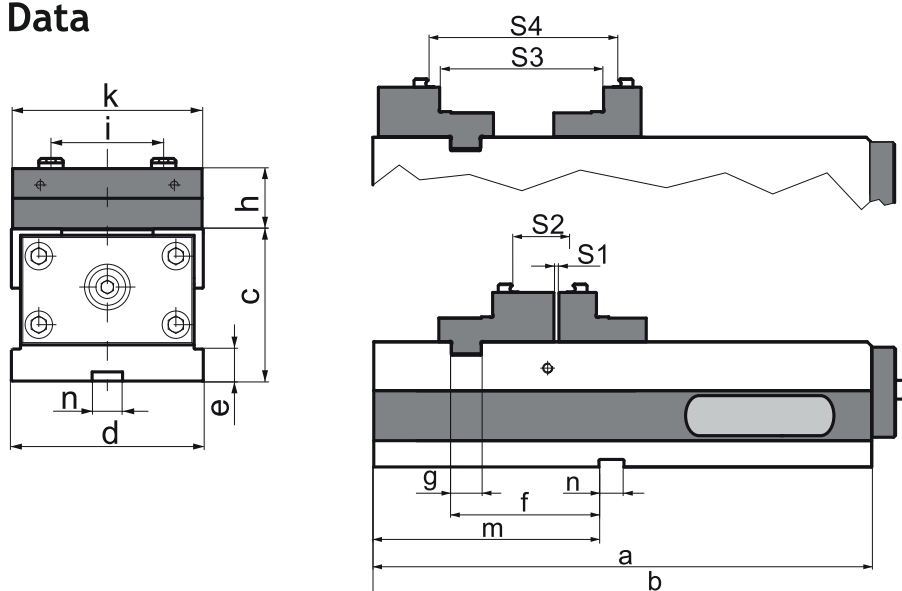

## Spindle cross-section

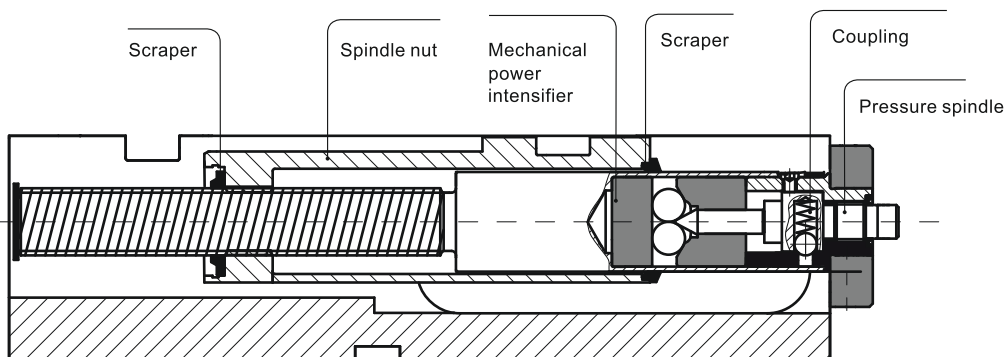

Variant	SC 125	
Dimensions/ Tolerances in mm	a	398
	b	429
	c	100
	d	126
	e	21
	f	118
	g	24
	h	39.4
	l	74
	k	124.4
m	180	
n	20	

Variant	SC 125
Clamping Range S1 in mm	0-182
Clamping Range S2 in mm	52-224
Clamping Range S2 round workpiece in mm	∅ 88-220
Clamping Range S3 in mm	131-313
Clamping Range S4 in mm	160-332
Max torque in Nm	30
Max. Clamping force in KN	40
Weight in kg	35

## Scope Of Supply

- Titan SC 125 Vise With Step Jaws - 1 No.
- Gripper Stud 2 Spike H6.7 - 4 Nos.
- Universal Jaw Assembly- 1 Set
- Work Piece Stopper- 1 No.
- Side Clamp - 4 Nos.
- Tenon 20x16 -2 Nos.

For clamping complex unmachined parts

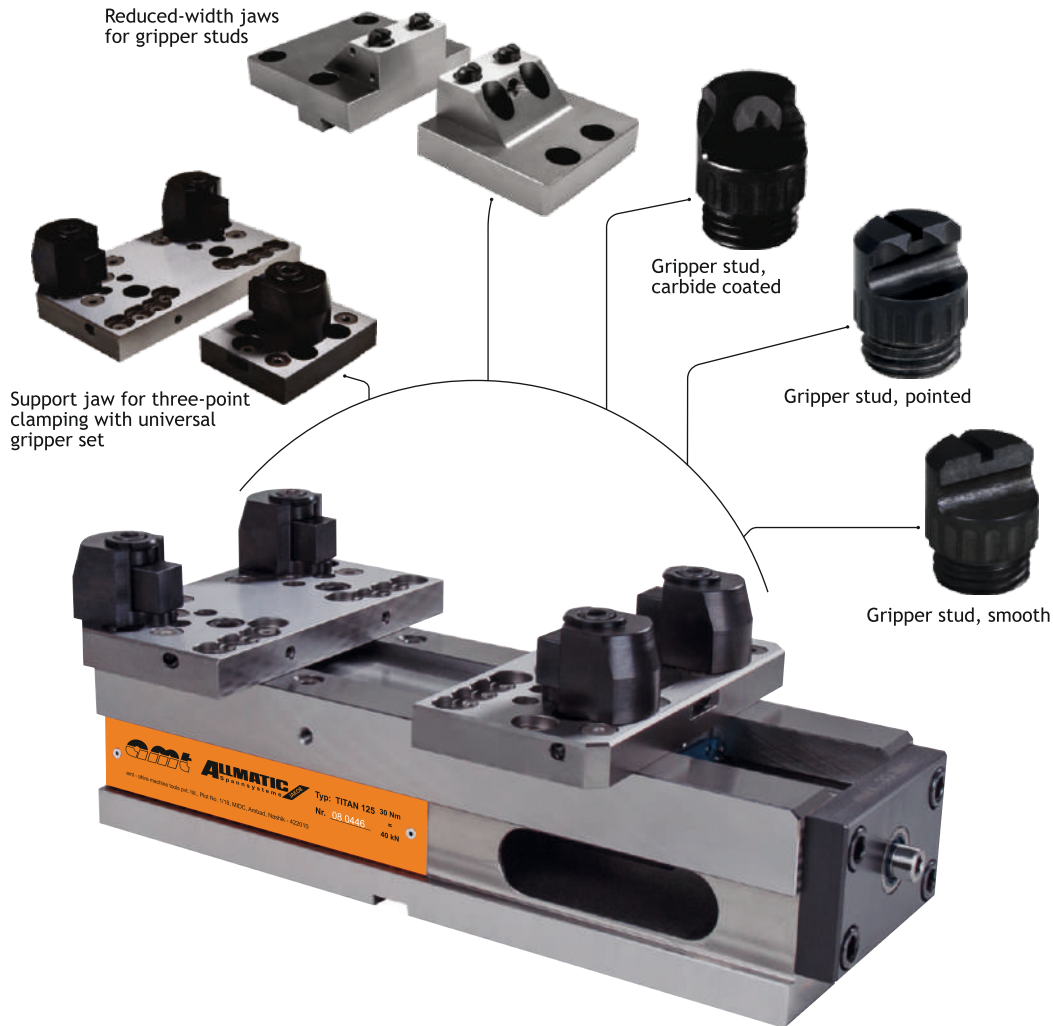

**NOTE:**

The movable jaw has no pendulum compensation. It is suitable for rectangular workpieces (saw cuts)  $/// \leq 0.5$  (concurrency less than or equal to 0.5 mm) or cylindrical workpieces  $O \leq 0.5$  (roundness less than or equal to 0.5 mm)

## Application Image



clamping unmachined round parts

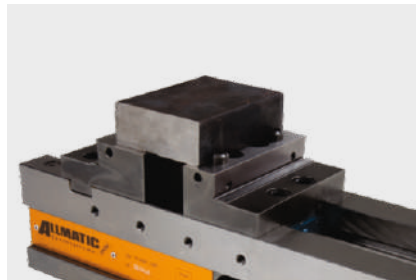

clamping unmachined quadratic parts



clamping pre-machined workpieces

## Pivoted Jaws



- Material: hardened steel
- For mounting various pull-down wedge elements, universal gripper set and gripper studs (pointed / smooth)
- Front surface can be used as clamping surface (hardened and ground)

### Pivot jaw:

- For clamping uneven workpieces
- To compensate for non-parallel clamping surfaces
- Supplied without wedge elements, gripper set and gripper studs (pointed/smooth)

\* Please order universal gripper set or gripper studs separately

## Application Image

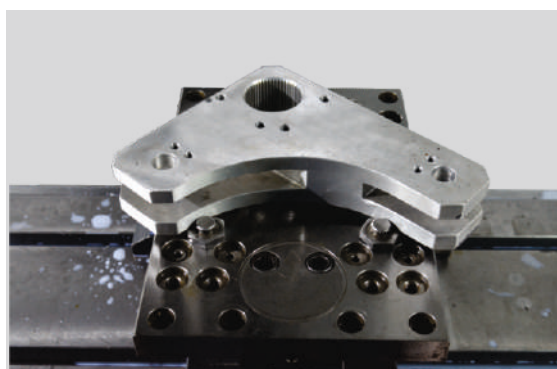
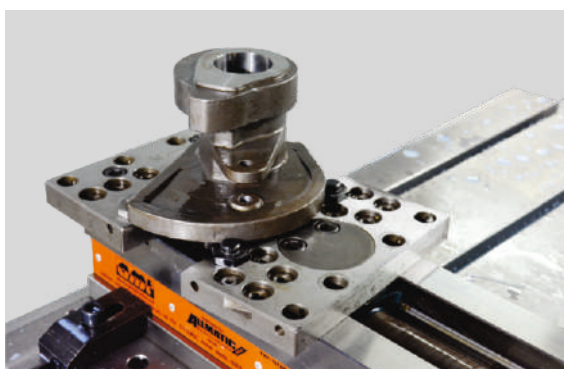

Pivoted Jaws with Gripper Stud

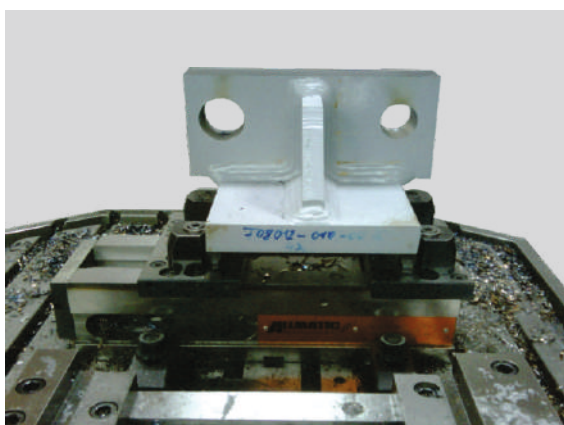

Pivoted Jaws with Universal Gripper

### Universal Gripper Set



- For clamping complex unmachined parts
- By reworking the individual elements of the universal gripper set, both the gripper height and the support height of the workpiece can be varied

Universal Gripper set Consist of:

- 4 x gripper studs
- 4 x gripper stud mounting
- 4 x supports
- 8 x shims
- Support bolts
- M10 fastening bolts in various lengths
- M6 threaded rods in various lengths
- Socket screw wrench
- Storage case

### Pointed Gripper Stud



- For clamping unmachined parts
- Least possible lost clamping margin
- Clamping height: adjustable from 4.5 to 6.0 mm

### Low Gripper Stud



- For clamping unmachined parts
- Least possible lost clamping margin
- Clamping height: adjustable from 3.0 to 4.5 mm

### Four-point Gripper Stud



- For clamping unmachined parts
- For soft materials such as aluminium
- Least possible lost clamping margin
- Clamping height approx. 4.5 mm to 6.0 mm

### Carbide coated Gripper Stud



- For clamping unmachined parts
- For quenched and tempered materials and flame-cut materials
- Least possible lost clamping margin, clamping height approx. 4.2 mm to 5.7 mm

### Smooth Gripper Stud



- With carbide coating for clamping pre-machined or harden workpieces
- Clamping height approx 7mm

### Round Gripper Stud



- For clamping unmachined parts
- For drilling through close to the edge
- Offers 6 mm clear space under the workpiece

\*Please order Accessories separately

## Scope Of Application

- Horizontal installation suitable for vertical CNC-controlled milling machines
- Ideal for use on 5-axis machining centres
- Reliable and fast clamping of unmachined parts, flame-cut and sawn materials with gripper jaws
- Clamping of parallel pre-machined workpieces with optional step jaws
- Gripper studs suitable for materials a strength of up to approx 1000 N/mm<sup>2</sup>

## Product Features:

- Optimum accessibility for 5-sided machining thanks to the combination of compact base and large clamping width
- Stamping and clamping in a single process, in the working area itself, without any additional accessories
- The movable/pivot support jaw allows different workpiece contours to be clamped
- Gripper studs can be changed without tools and are easy to adjust by hand
- Operation with a torque wrench max. 30 Nm high-pressure spindle with power intensification.



Robust and compact base made of GGG 60

M8 thread for workpiece stop

Hardened, ground and polished guideway



Holes in the clamping shoulder for fastening to the machine table itself

Precision aligning slots (longitudinal/transverse) and a positioning hole in the bottom surface for optimal alignment on the machine table

Outlet for coolant and chips

**!** Optional: mounting holes in the bottom surface for zero-point clamping systems are possible

## Application Image



## Technical Data

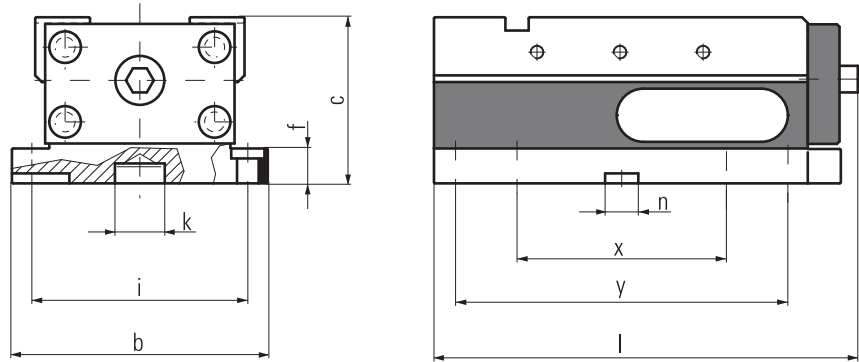

### Technical data

Variant		125
Dimensions/ Tolerances in mm	b	154
	c	100
	f	21
	l	130
	k	∅ 30 H8
	l	256
	n	20H7
	t	∅ 13
	x	127
	y	200

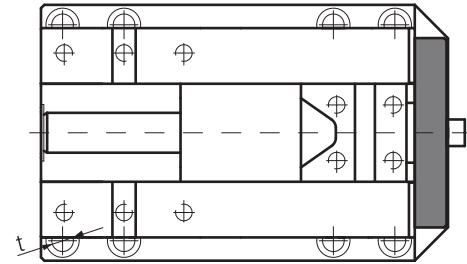

Jaw width	125
Max. torque in mm	30
Max. clamping force in kN	40
Weight in kg	18

### For conventional clamping of workpieces

On the following pages you will find a wide range of jaws suitable for clamping pre-machined workpieces.

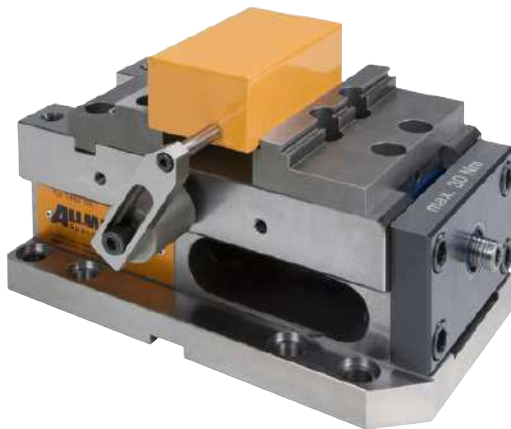

### For conventional clamping of workpieces

Varying types of unmachined part can be clamped quickly and securely using the support jaws and the reduced-width jaws. Jaws for gripper clamping can be found on the following pages.



### Scope Of Supply

- High-pressure vise without jaws - 1 No.
  - Fastening bolts M12X35mm - 4 No.
  - Socket screw wrenches - 3 No.
- (Please order clamping jaws separately)

## Scope Of Application

- Horizontal installation - suitable for vertical CNC milling machines
- Ideal for use on five-axis machining centres due to its compact design
- Depending on the clamping jaws, both pre-machined workpieces and unmachined parts can be clamped
- With support jaws, unmachined parts with varying types of flame-cut and sawn materials and even complex castings can be clamped safely and economically. Gripper studs suitable for materials of mechanical strength of up to approx. 1000N/mm<sup>2</sup>

## Product Features

- Alloy steel body & case hardened
- The centre is adjustable. The position of the workpiece stays within set boundaries.
- Repeating accuracy  $\pm 1/100$ mm for angled workpieces
- Guide ground, polished and paired
- Clamping range presetting via adjustment of clamping jaws along transverse slots of spindle nuts
- Moulding and clamping in a single step, directly in the work area - no auxiliary aids required
- Use with a torque wrench - max. 70 Nm
- Fully enclosed and maintenance-free high-pressure spindle-high chip protection, minimum cleaning requirements, constant clamping forces up to 40 kN.



Gripper stud, pointed for clamping raw material (1. clamping station)

M10 thread for mounting HD jaws

Robust base made of GGG 60

Hardened ground and polished guideway

Step jaws for gripper studs for the first and second clamping

Outlet for coolant and chips

Accurate aligning slots (longitudinal/transverse) in the ground bottom surface for optimum alignment on the machine table

M8 thread for workpiece stop

## Application Image

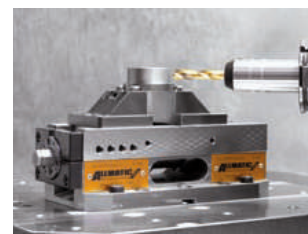
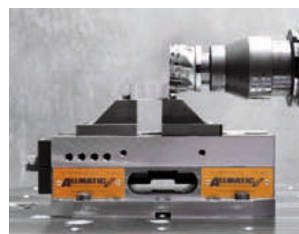
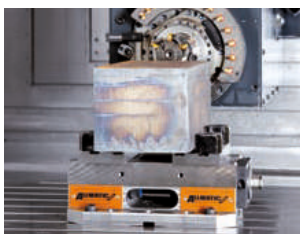

## Technical Data

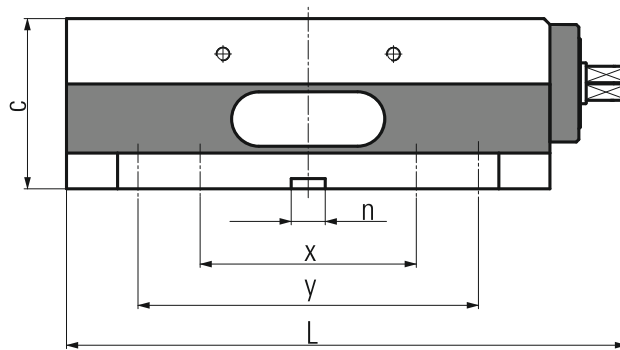
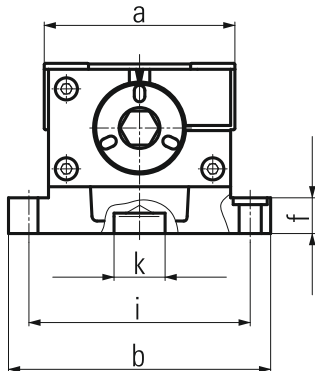

Variant	125
Max. torque in NM	70
Max. Clamping force in kN	40
Weight in kg	20.7

Variant	125	
Dimensions/ Tolerances in mm	a	112
	b	154
	c	100
	f	21
	i	129/130
	k	∅ 30 H8
	l	329
	n	20H7
	r	182
	s(traverse)	46
	t	∅ 13
	x	127
y	200	

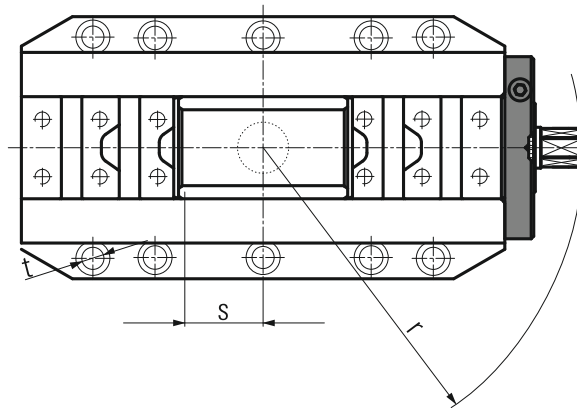

### Scope Of Supply

- 1 high-pressure vise without jaws
- 2 combination wrenches
- 6 fastening screw, M12X35mm
- 2 socket screw wrenches
- 1 wrench socket
- ★ (please order clamping jaws separately)

### Console



- For raising the Centro Gripp 125
- Improved access for five-sided machining
- The mounting hole pattern of Centro Gripp 125 and console is offset slightly in order to enable mounting in tables with parallel T-slots as well as in tables with cross slots.

# CLAMPING RANGES— CENTRO GRIPP

## Support jaws with gripper studs

You can find the clamping ranges of the other jaws for conventional clamping on the following pages of accessories.

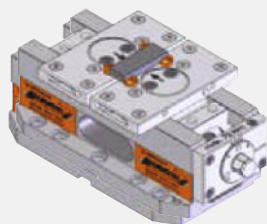

Min. clamping range	25 mm
Min. clamping width	73 mm



Max. clamping range	247 mm
Max. clamping width	at least 150 mm or larger

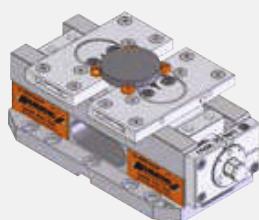

Min. clamping range	Ø 80 mm
---------------------	---------

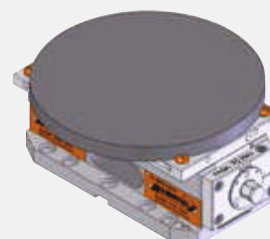

Max. clamping range	Ø 250 mm
---------------------	----------

## Support jaws with universal gripper set

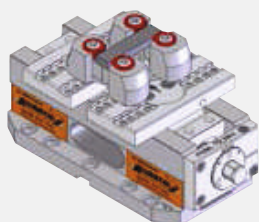

Min. clamping range	0 mm
Min. clamping width	90 mm

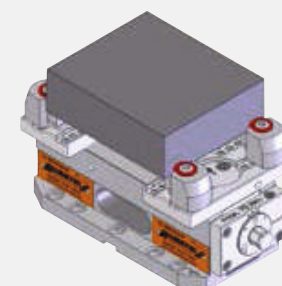

Max. clamping range	195 mm
Max. clamping width	at least 165 mm or larger

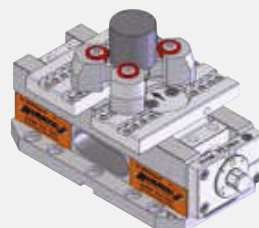

Min. clamping range	Ø 100 mm
---------------------	----------

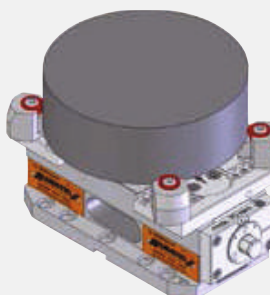

Max. clamping range	Ø 230 mm
---------------------	----------

## Scope Of Application

- Ideal for use on 5 axis machining centers
- Horizontal installation - Suitable for vertical machining centers
- Vertical installation - Suitable for Horizontal machining center
- Suitable for CMM insertion mountings.

## Product Features

- Alloy steel body & case hardened
- Mechanical centric vise
- Clamping force: 28 kN with 100Nm
- Massive stable base part from tool steel - without holes
- Reversible step jaws, width 67mm
- Threads on high and stepped sides for step strips and customization.
- V notch for clamping round work pieces with a diameter of  $10\text{ mm} \leq d \leq 45\text{ mm}$

- Hardened slideway and jaws
- Spindle with a high tensile strength of  $700\text{N/mm}^2$ , good sliding properties and a very high wear resistance
- Clamping range 0mm – 164mm

## GRIPP Clamping

With the clamping jaw systems you can clamp parallel workpieces safely and quickly. Stamping and clamping takes place in one work step.

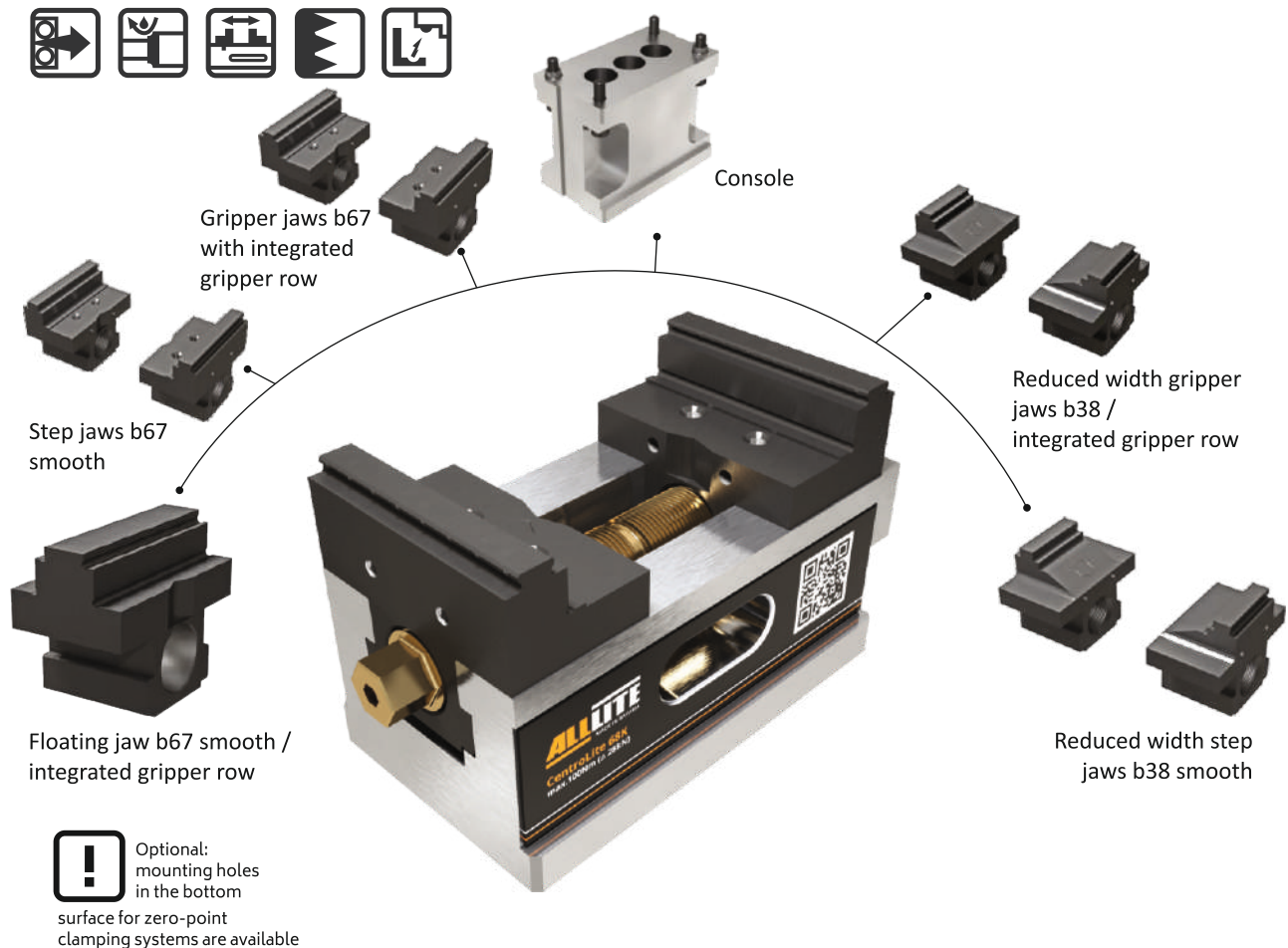

## Application Image

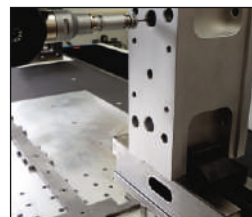
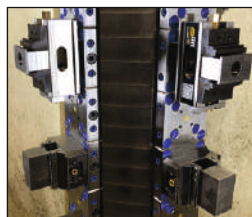
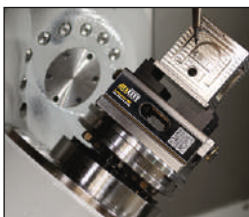

## Technical Data

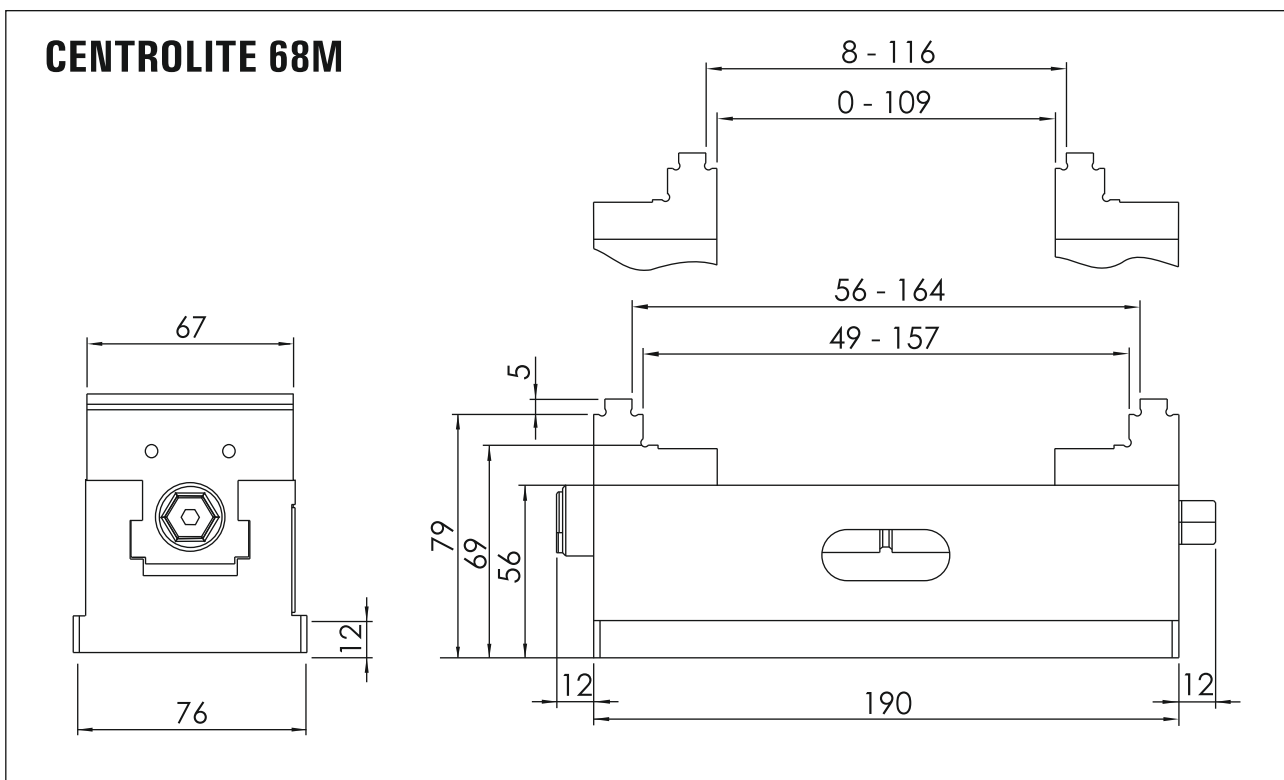
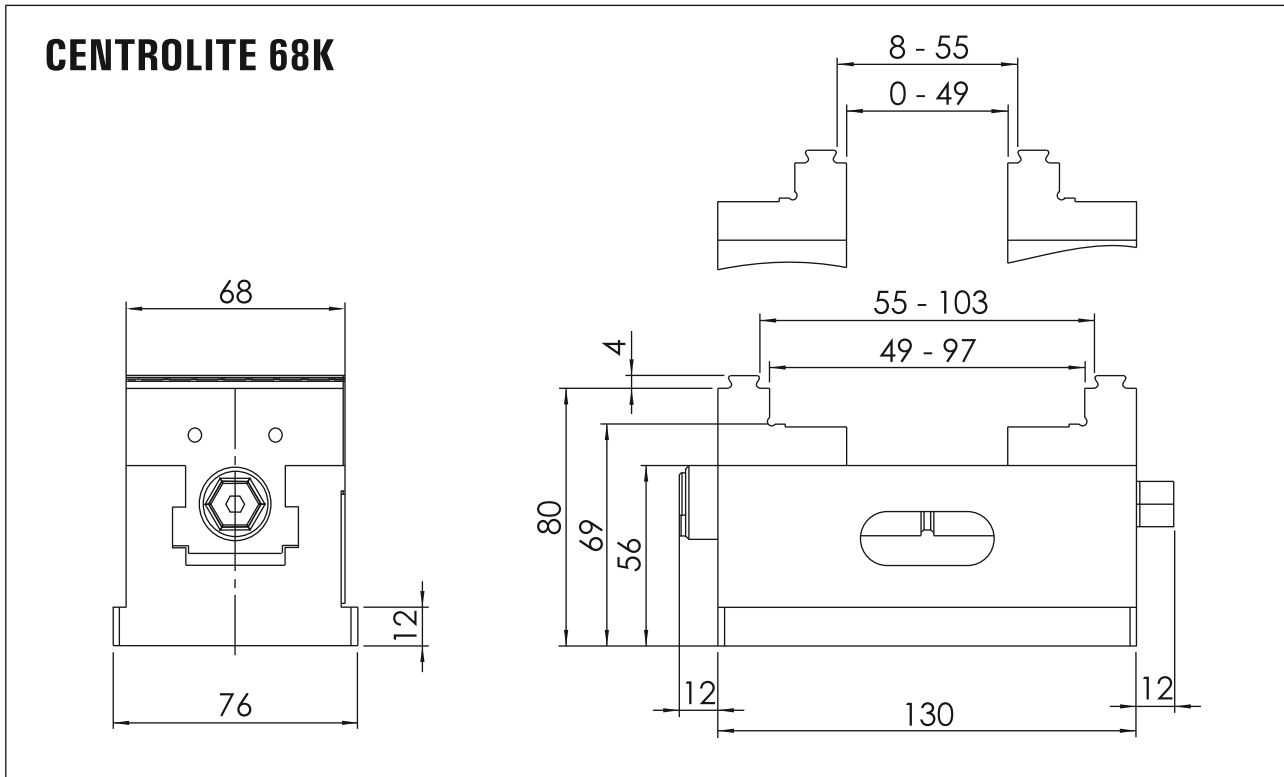

- Scope of Supply**
- Centrolite 68 K/M Vise With Gripper Step Jaws - 1 No.
  - Ratchet With Socket - 1 No
  - Side Clamps - 4 Nos.

### Floating jaw b67 smooth / integrated gripper row

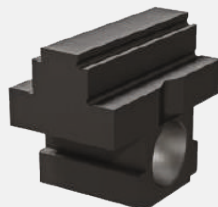

- All surfaces hardened
- Without inner thread
- Step jaw, width 67mm
- V notch for clamping round workpieces

### Step jaws b67 smooth



- All surfaces hardened
- Step jaw, width 67mm
- Threads on high and stepped sides for step strips and customization
- V notch for clamping round workpieces

### Gripper jaws b67 with integrated gripper row



- All surfaces hardened
- Gripping jaws with integrated gripper row, width 67mm  
Lost clamping margin of 4 mm  
Suitable for pre-milled workpieces up to 1000N/mm<sup>2</sup> and raw materials up to 550N/mm<sup>2</sup> (max deviance of parallelism 0.3mm)  
Threads on high and stepped sides for step strips and customization.
- V notch for clamping round workpieces

### Console



- For raising the ALLLITE
- Improved access for five-sided machining
- The mounting hole pattern of ALLLITE and console is offset slightly in order to enable mounting in tables with parallel T-slots as well as in tables with cross slots.

### Reduced width gripper jaws b38 with integrated gripper row



- All surfaces hardened
- Gripping jaws with integrated gripper row, clamping width of the jaw 38mm
- Lost clamping margin of 4 mm
- Suitable for pre-milled workpieces up to 1000N/mm<sup>2</sup> and raw materials up to 550N/mm<sup>2</sup> (max deviance of parallelism 0.3mm)

### Reduced width step jaws b38 smooth



- All surfaces hardened
- Step jaw, clamping width of the jaw 38mm

## Scope Of Application

Ideal for use on 5-axis machining centers  
 Conventional clamping and GRIPP clamping possible

## Product Features

- Alloy steel body & case hardened
- Telescopic spindle, interference contour remains unchanged
- Central, simple programming without zero point offset
- The allowance of the material is symmetrically distributed
- Accessibility of the workpiece depends on the chuck capacity
- Symmetrical construction shape
- workpiece remains central and parallel
- Support height of the workpiece 192 mm
- Quick change jaw system, tool-free jaw change due to quick-action closure within 10 seconds per jaw pair

- Reversible jaws: for min. / max. chuck capacities with one pair of jaws
- Provided as standard with locating holes for a zero point clamping system, inside micrometer 200
- Integrated scaling for fine adjustment of the central position
- Low weight (without jaws): K=17.5kg/ M=19.5kg
- Clamping force 30 kN at 45 Nm linear
- Operation with torque wrench

## GRIPP Clamping

With the clamping jaw systems you can clamp parallel workpieces safely and quickly. Stamping and clamping takes place in one work step.

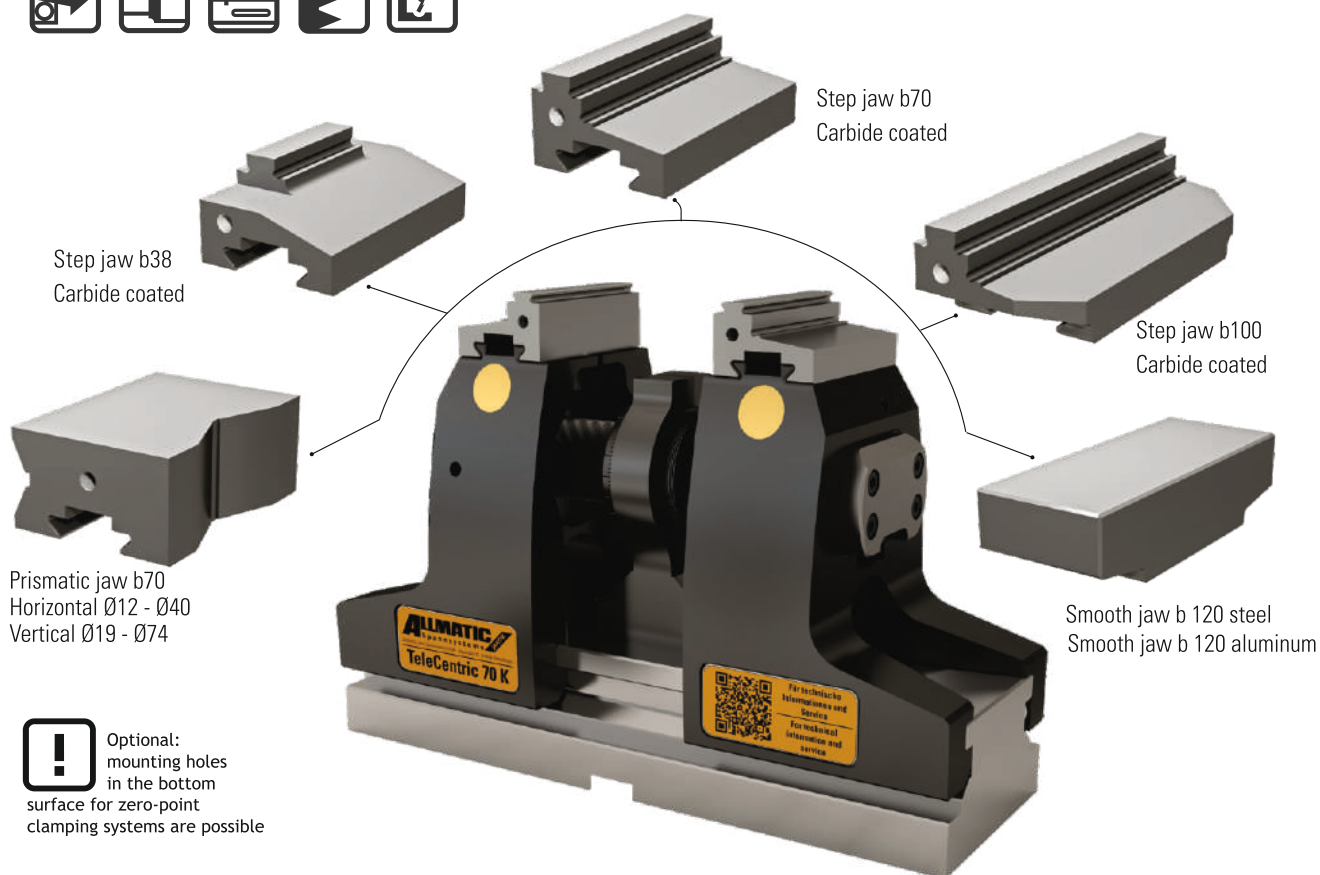

## Application Image

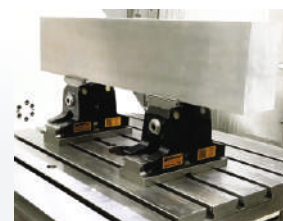
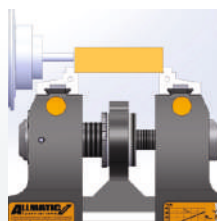
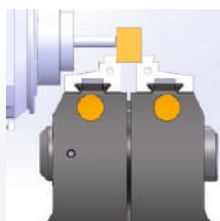
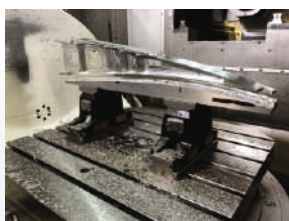

# TELECENTRIC 70 K

# TELECENTRIC 70 M

## Clamping range conventional clamping

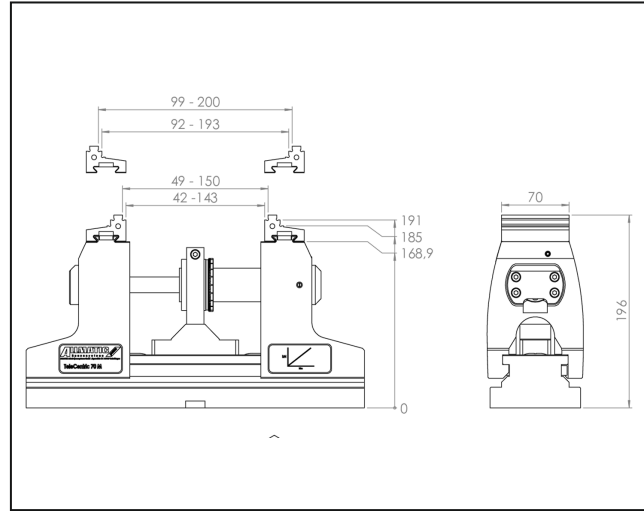
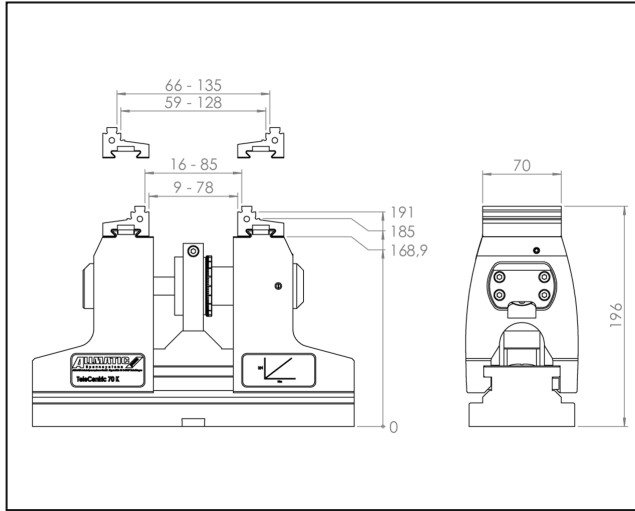

## Clamping range GRIPP clamping

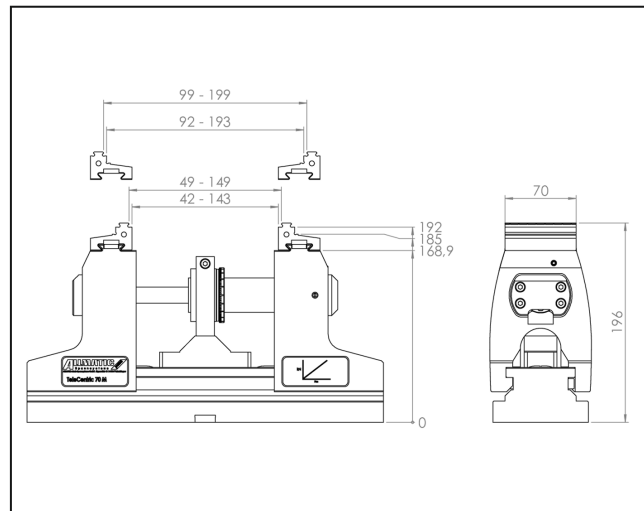
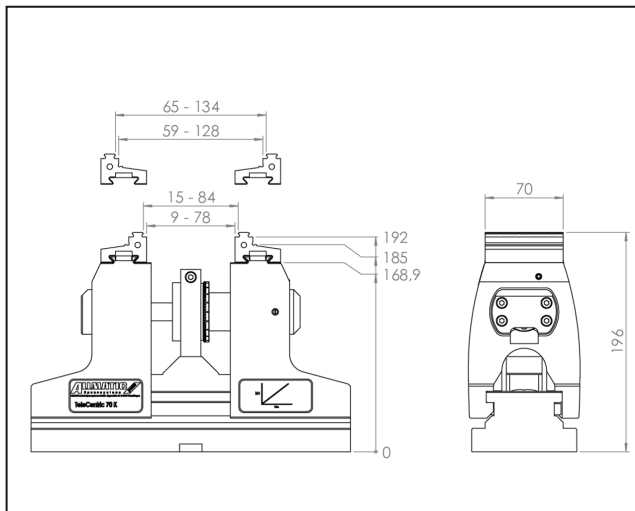

## Technical data

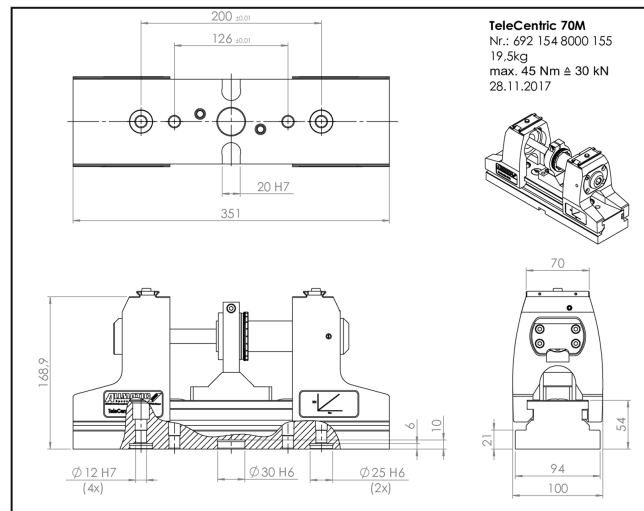
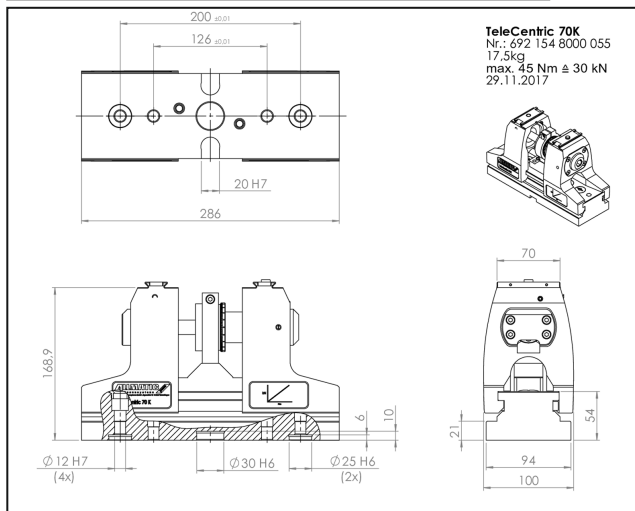



## SELF CENTRIC VISE – SCV 125/225

### Scope Of Application

- Ideal for use on 3, 4 & 5 Axis Machining centers due to its compact design
- Horizontal Installation-Suitable for Vertical Machining Centers
- Vertical Installation - Suitable for Horizontal Machining Centers

### Product Features

- Heavy duty high precise self-centric clamping vice with good repeatability
- Compact design with best accessibility
- Clamping force - 20 KN with 100Nm
- Interface for ZPS clamping and mounting holes as standard
- Spindle screw Blackodising (for high hardness, wear, corrosion resistance and excellent lubricity)
- 4 Bolt jaw mounting for Increased Clamping Force
- Provision of M5 holes for mounting additional Jaws
- Serrated gripper teeth for superior bite with 45° Dovetail provision
- Featuring a dowel pin for better accuracy in Jaws
- High material savings due to minimal clamping edge requirements
- 3mm gripp clamping is possible

### Gripp Clamping

- With the clamping jaw systems you can clamp parallel workpieces safely and quickly.
- Stamping and clamping takes place in **one work step**.



Provision of M6 holes for mounting additional Jaws

Serrated Gripper teeth for superior holding

45° Dovetail built into hard jaw

M8 Thread for workpiece stop



Hardened and ground Guide ways

Spindle screw for high hardness, wear & corrosion resistance and excellent lubricity

## Technical Data

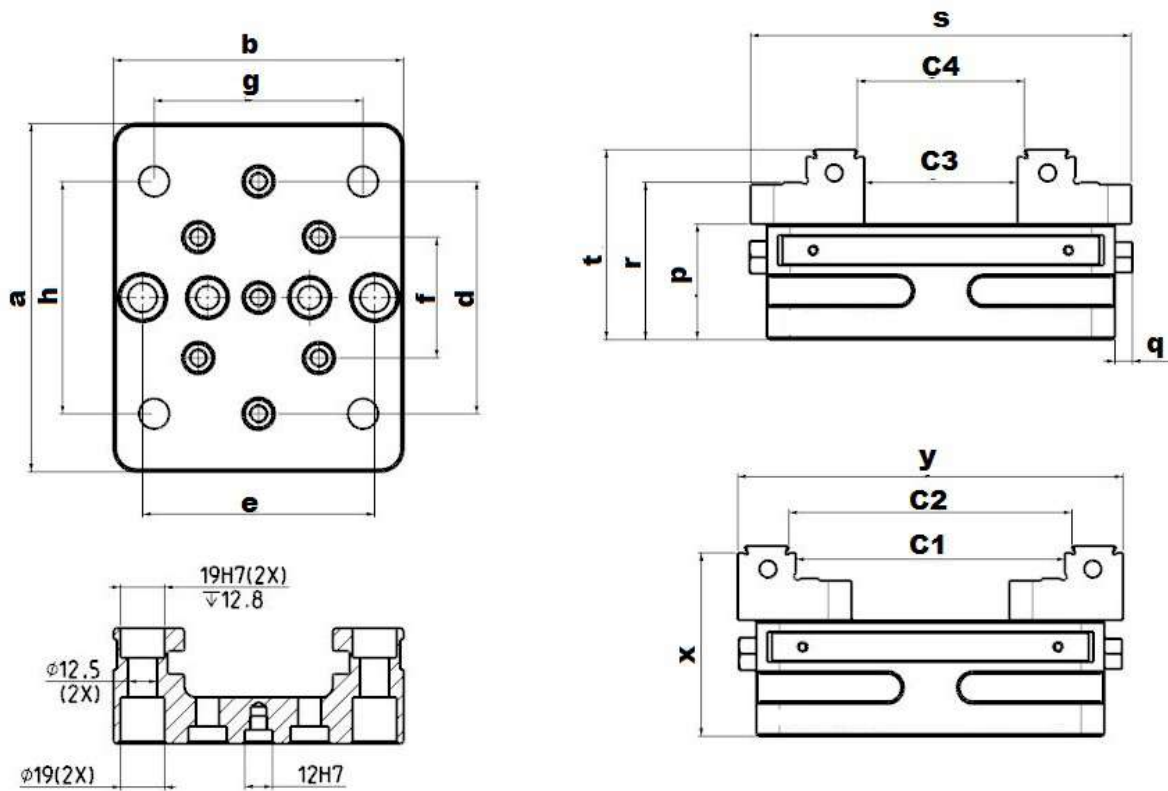

Variant	SCV 125	SCV 225	
Dimensions in mm	a	150	250
	b	125	125
	e	100	96
	f	52±0.01	96±0.02
	g	N/A	100
	h	N/A	200
	p	50	50
	q	7.5	7.5
	r	68	68
	s	167	267
	t	82	82
	x	79	79
	y	166	266
	C1	120	220
	C2	125	225
	C3	68	168
C4	73	173	

Variant	SCV 125-125	SCV 125-225
Dimensions (mm)	150X125X82	150X225X82
Clamping Range (Forward Jaws) (mm)	6-73	6-173
Clamping Range ( Reversed Jaws) (mm)	55-125	55-225
Maximum Clamping Force (kN)	20	20
Maximum Torque Force (Nm)	100	100
Weight (Kg)	8	11

### Scope Of Supply

- Self Centric Vise SCV 125-125/125-225  
with Clamping Jaws - 1 No
- Work Piece Stopper -1 No.
- Side Clamp - 4 Nos
- Ratchet With Socket - 1 No

## SELF CENTRIC VISE - ACCESSORIES

### Soft Jaws

- For holding parts that would be difficult to fixture with standard, flat vise jaws during machining.
- Suitable for Profile and Irregular shape workpiece.



\* On Request

### Intermediate Jaw

- For clamping two work pieces simultaneously
- Installation between both the jaws

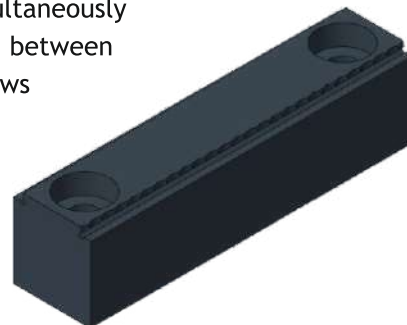

\* On Request

### Riser Block/Console

- For raising the Self Centric SCV 125/225 Improved access for five-sided machining



\* On Request

### Zero Point System

- For Quick clamping and alignment of Vise Allows you to clamp parts with accuracy, speed, ease and flexibility using retractable nipples and fast-closing clamps



\* On Request

### Adaptor Plate

- Adaptor plate for 4th and 5th axis Rotating axis - Diameter 160 mm and 200 mm



\* On Request

### Pyramid

- The pyramid work holding bundles facilitate clamping of three individual components in one fixture and completed in a single setup.

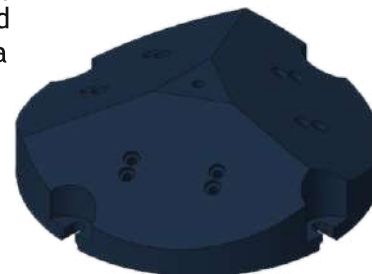

\* On Request

# BACK TO BACK LC 125/Titan SC 125

## Scope Of Application:

- Modular clamping system for horizontal machining centres

## Product Features:

- Alloy steel body and case hardened
- Comprises standard single LC 125/Titan SC 125 or combination of LC 125 & SC 125
- Clamping force increments can be preset. at most, two revolutions are required to reach the max. clamping force
- Preselectable and reproductible clamping forces enable the workpiece position to be repeated within a tolerance of less than 0.01 mm
- Individual adaption to your machine (pallet, traverses and workpieces) is possible
- Two clamping points permit 3-sided machining

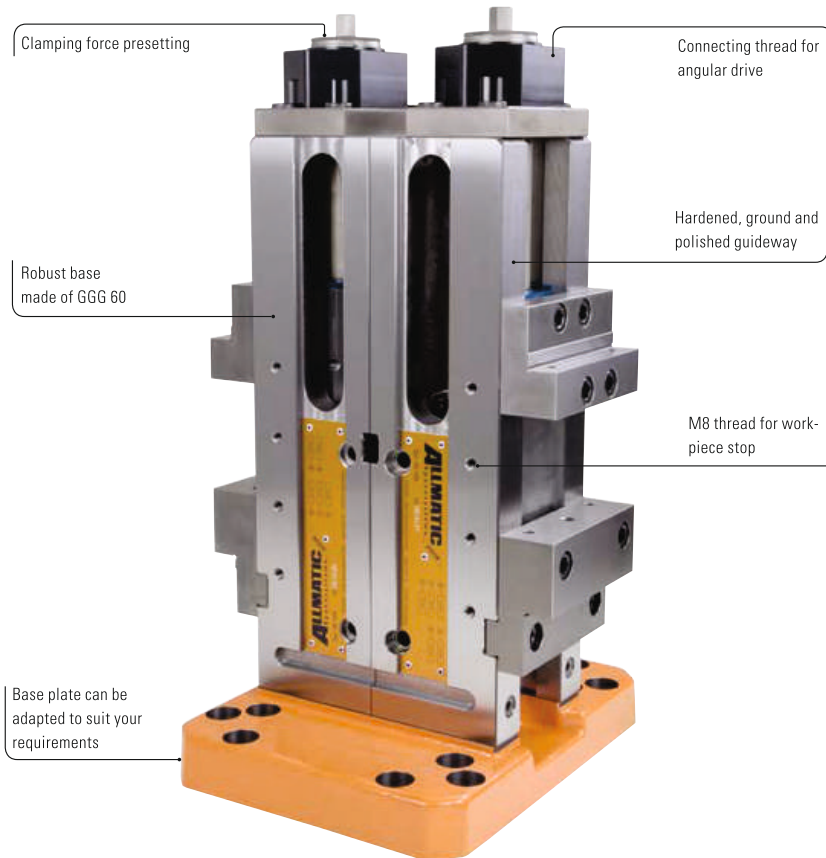

## Application Image

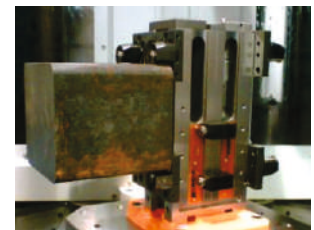
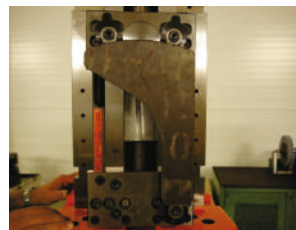

## Technical Data

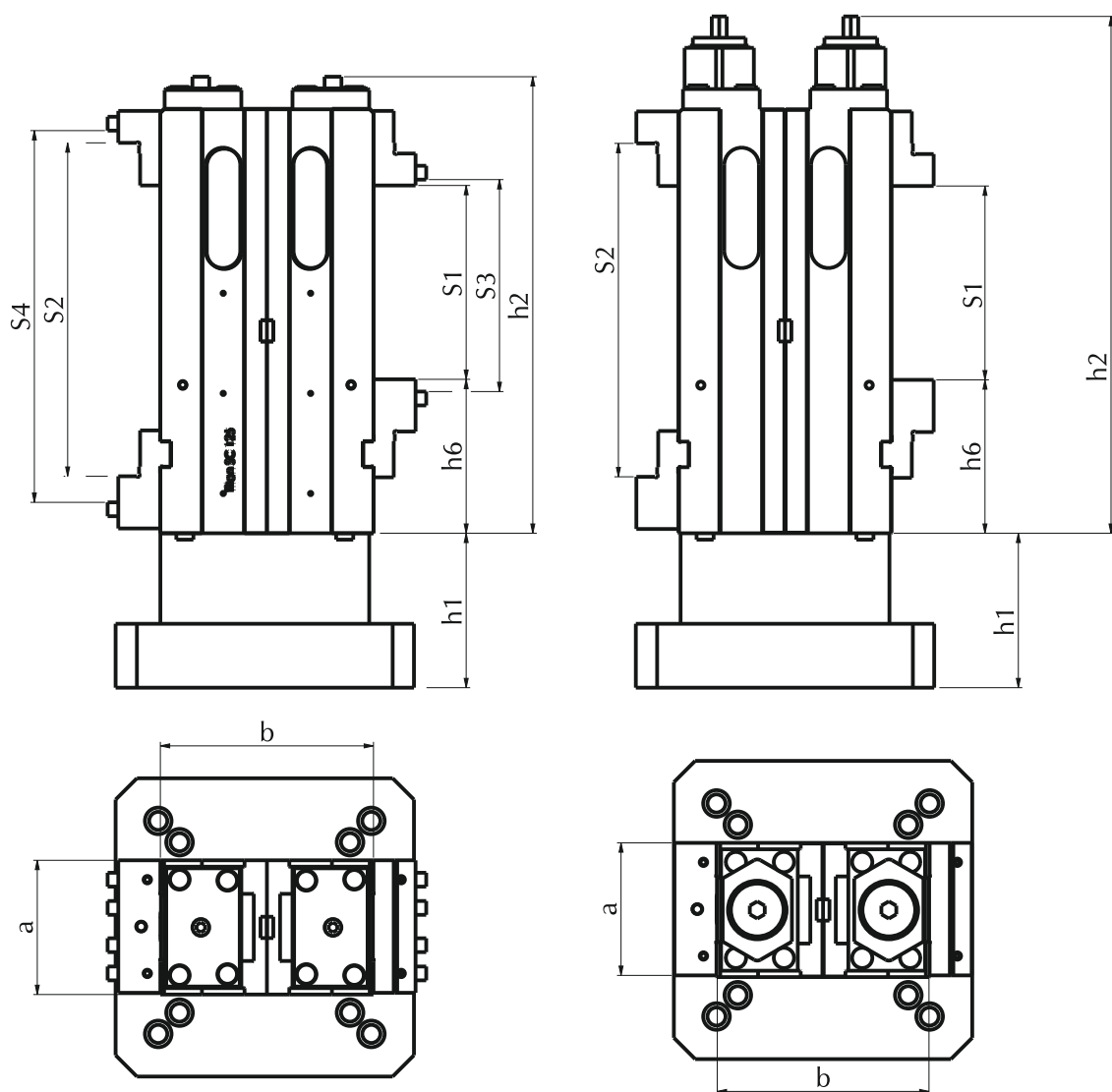

Variant		LC 125	TITAN SC 125
Dimensions in mm	a	125	125
	b	200	200
	h1	145	145
	h2	483	429
	h6	144	144

Type	LC 125	TITAN SC 125
Clamping range S1 in mm	0-182	0-182
Clamping range S2 in mm	131-313	52-224
Clamping range S2 round workpiece in mm	-	∅ 88-220
Clamping range S3 in mm	-	131-313
Clamping range S4 in mm	-	160-332
Max. torque in Nm	40	30
Clamping force increments	4	-
Max. clamping force in kN	40	40



# WEDGE CLAMP

## Working Principle

Wedge clamp functions on the principle that it expands as cap screw is tightened down which moves centre clamping wedge downwards and simultaneously both jaws slide outwards and clamp the work piece firmly. Tightening and loosening of cap screw will return the centre clamping wedge over an internal return spring to its original position so the clamping method is very effective and time saving

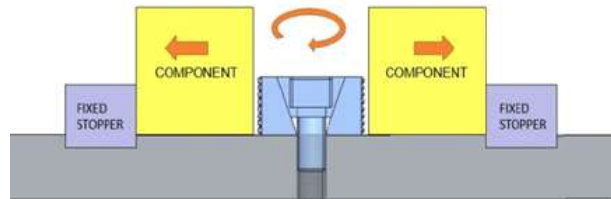

## Application

- Generic & dedicated fixturing for VMC, HMC & 5 axis machines.
- For designing fixtures for inspection & quality labs.

## Product Features

- Tool grade steel body.
- Hardened with electroless nickel plating.
- Expands evenly and apply balanced workholding pressure.
- Free tool access to the workpiece.
- Cross wedge structured design clamps workpiece firmly.
- Light in weight with quick setup time.
- Ideal for multiple clamping but also suitable for individual clamping.
- Chip free design (Internal return springs).

## WEDGE CLAMP WITH STANDARD JAWS (KD-STJ)

### TECHNICAL SPECIFICATIONS

Wedge clamp is provided with smooth clamping face & fastening screw thread is provided to accommodate various additional customized jaws to workpiece geometry.



Wedge Clamp

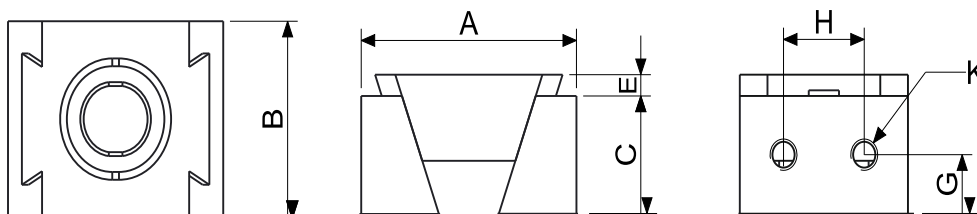

MODEL	A			B	C	E	G	H	K	CLAMPING SCREW ( DIN 912 )	TIGHTENING TORQUE (Nm)	CLAMPING FORCE (KN)	WEIGHT (gm)
	MIN	MEAN	MAX										
KD-STJ-1	32	34	36	25	15	4	7.5	12	4XM4	M8	20	15	70
KD-STJ-2	42	45	48	30	24	4	11.5	12	4XM4	M12	65	30	165
KD-STJ-3	56	60	64	40	30	4	15	24	4XM5	M16	120	50	390

Note : Wedge clamp also available in Stainless Steel

## WEDGE CLAMP WITH SERRATED JAWS(KD-SJ)

### TECHNICAL SPECIFICATIONS

Wedge clamp with serrated jaws is a special purpose clamp. Serrations on both sides of the jaws hold workpiece firmly in any condition as they create high friction.

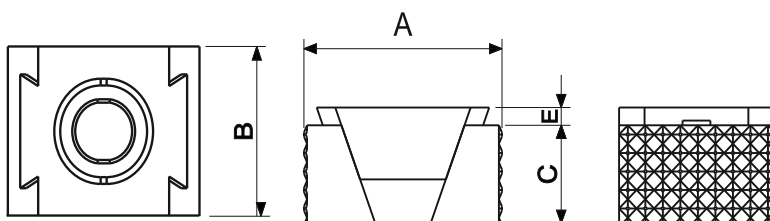
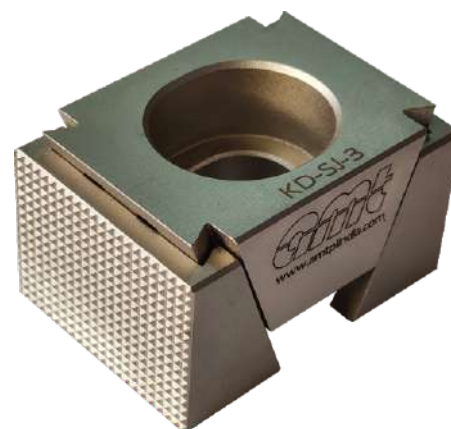

MODEL	A			B	C	E	CLAMPING SCREW ( DIN 912 )	TIGHTENING TORQUE (Nm)	CLAMPING FORCE (KN)	WEIGHT (gm)
	MIN	MEAN	MAX							
KD-SJ-1	32	34	36	25	15	4	M8	20	15	70
KD-SJ-2	42	45	48	30	24	4	M12	65	30	165
KD-SJ-3	56	60	64	40	30	4	M16	120	50	390

Note : Wedge clamp also available in Stainless Steel



## RAIL VISE

### Application

AMT Rail vise features a range of components that are suitable for clamping different work piece types, sizes and materials on all types of work holding platforms and machining centers.

### Product Features

- AMT Rail vise are highly flexible, and they quickly and easily clamp multiple small or large work pieces.
- Can be used on VMC/4th axis/HMC machine-for efficient precision machining
- Horizontal installation - great variability and flexibility
- Modularly constructed clamping system, which has its advantages in the versatile application possibilities.
- Through use of a wide array of fixed jaws and wedge clamps, this clamping system is adapted to your needs.
- Riser blocks/parallels. These are used to lift up the workpiece from base.
- Reproducible clamping forces are achieved using a torque wrench.
- Reproducible clamping range is achieved using scale.

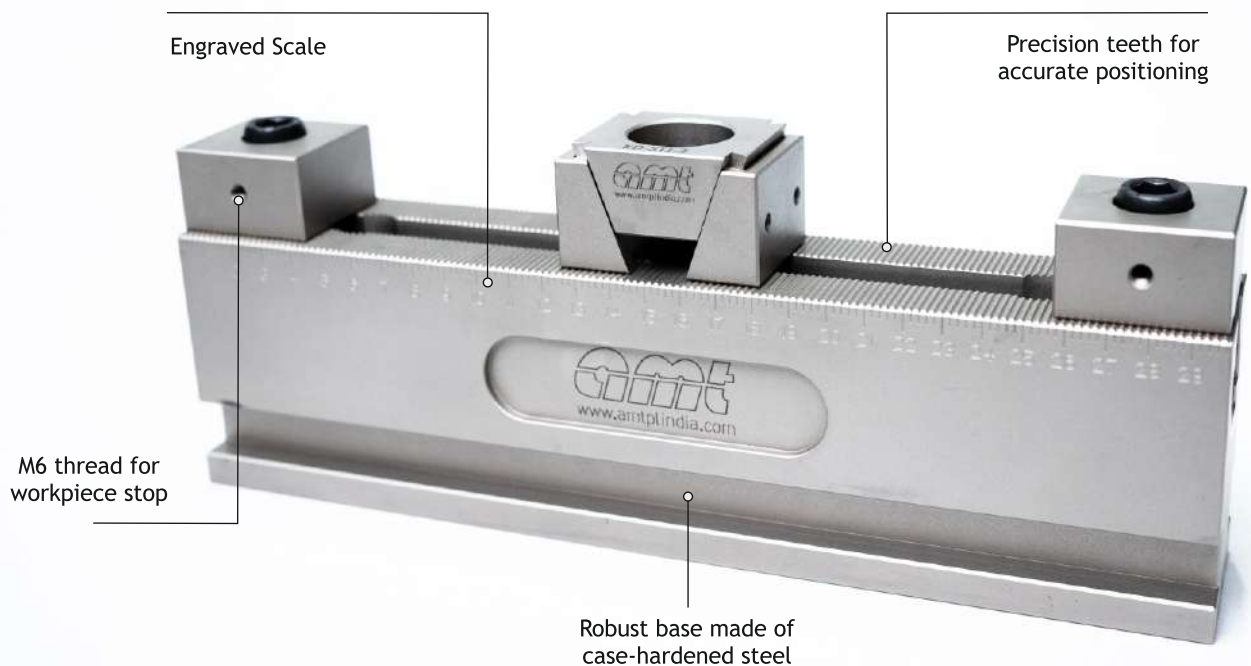

## RAIL VISE BODY

### Application

- Optionally designed for one or more workpieces.
- For rapid clamping of work pieces for machine processing. Through use of a wide array of fixed stops and wedge clamps, this clamping system is adapted to your needs.

### Product Features

- Alloy steel body & case hardened 58 to 62 HRC.
- Excellent ease of operation guarantees optimal handling for every application
- Fast adjustment for clamping range pre-setting through precision scale marking.
- Accurate positioning and alignment because of the rack teeth provided on both the body and the fix jaws.
- Rack teeth pitch accuracies (+/-0.02 mm).
- Operation with the Allen key.

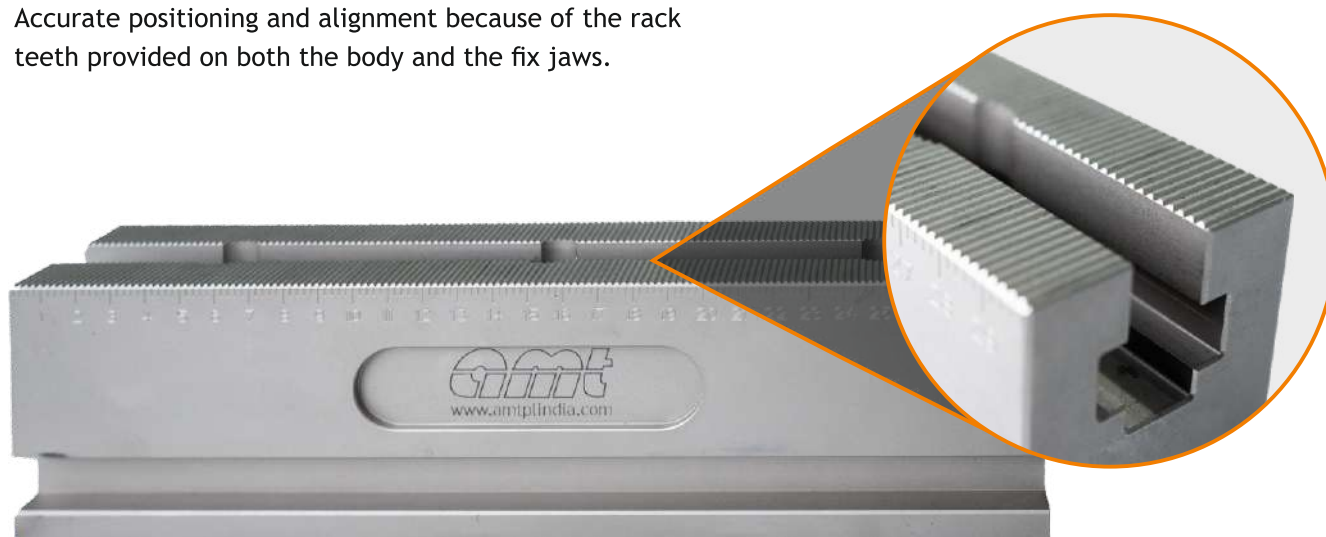

## FIXED CLAMPING JAW WITH STANDARD & SERRATED SURFACE

### Application

- The fixed stop is positioned on the clamping rail via the tightening bolt and grips, positively interlocked, on the 2 mm serration.
- Workpieces can be positioned and clamped with great clamping force.

### Product Features

- Alloy steel body & case hardened 58 to 62 HRC.
- Excellent ease of operation guarantees optimal handling for every application.
- Provision to fix workpiece stop.



# Technical Data

Rail Vice

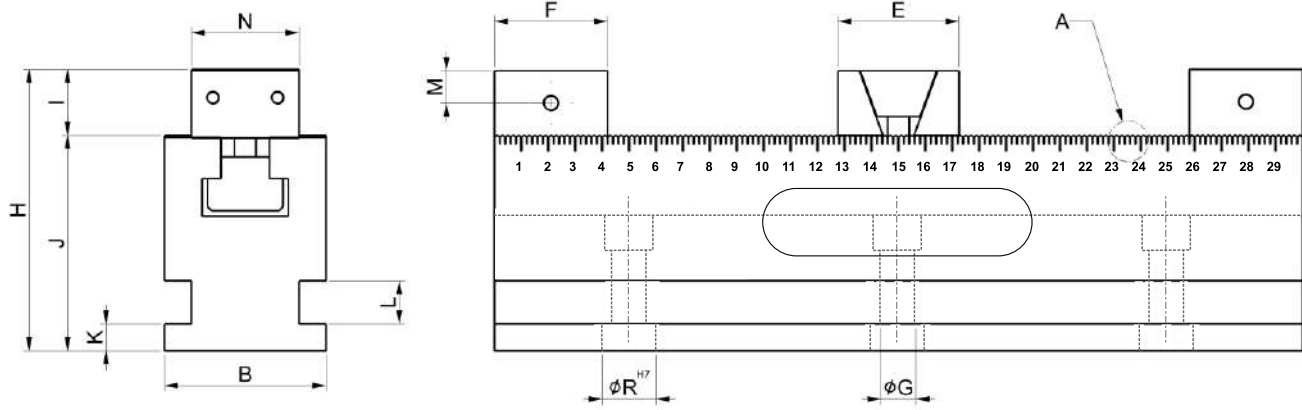

## Scope Of Supply

- Rail Body 300/500 - 1 Nos.
- Fix Jaw - STJ - 2/3 Nos.
- Wedge Clamp With Standard Jaw KD-STJ-2/KD-STJ-3 - 1/2 Nos.
- Side Clamp-RL - 4/6 Nos
- Workpiece Stopper Plate-RL - 2/3 Nos.

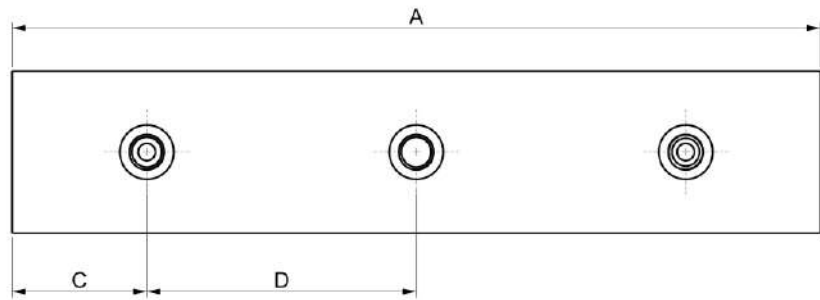

MODEL	A	B+/-0.05	C	D+/-0.01	E	F	G	H	I	J	K	L	M	N	R
KD-STJ-2 RL-300	300	60	50	100	42	42	13	105.5	25.5	80	15	16	12	40	20
KD-SJ-2 RL-300	300	60	50	100	42	42	13	105.5	25.5	80	15	16	12	40	20
KD-STJ-3 RL-500	500	60	50	200	60	42	13	110.5	30.5	80	15	16	12	40	20
KD-SJ-3 RL-500	500	60	50	200	60	42	13	110.5	30.5	80	15	16	12	40	20

**AMT  
RAIL VICE  
ACCESSORIES**

**STEP JAW**

Suitable for through machining.  
Maximum tool access to the work piece.

**WORK PIECE STOPPER**

Lateral stop for positioning work pieces.  
Stop is screwed to the fixed jaw and can be moved.

**POSITIONING BUSH**

For Precision positioning & quick aligning  
Hardened & ground

**SIDE CLAMP**

For mounting of the clamping rail on the machine table with slots.

# APPLICATION IMAGES

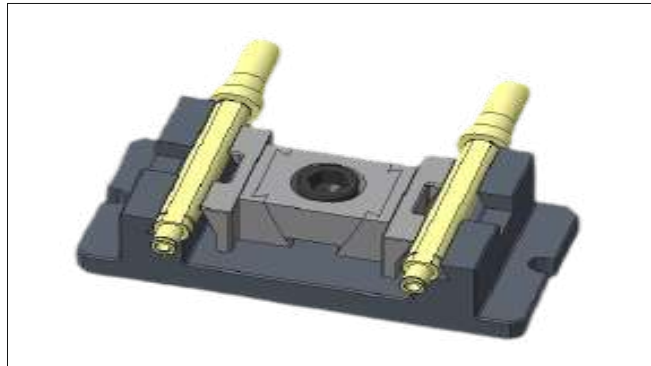
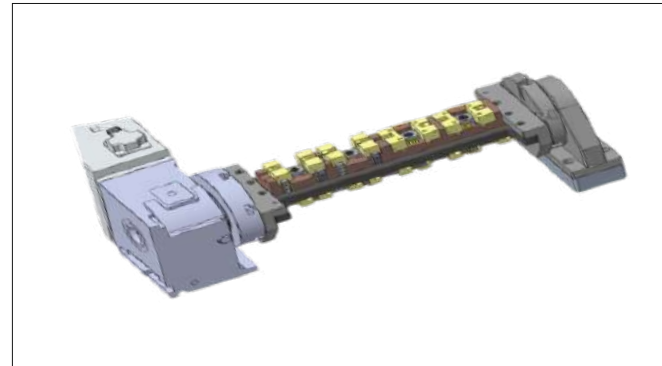
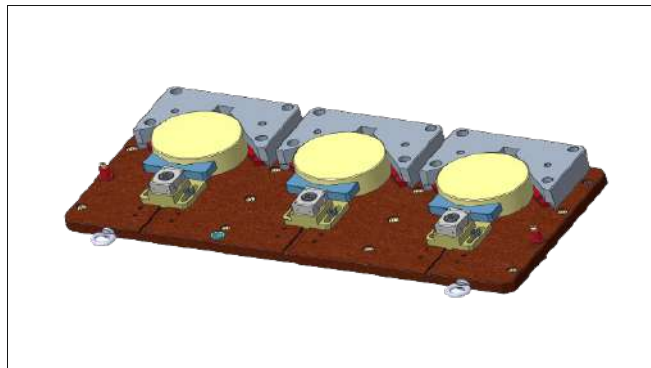
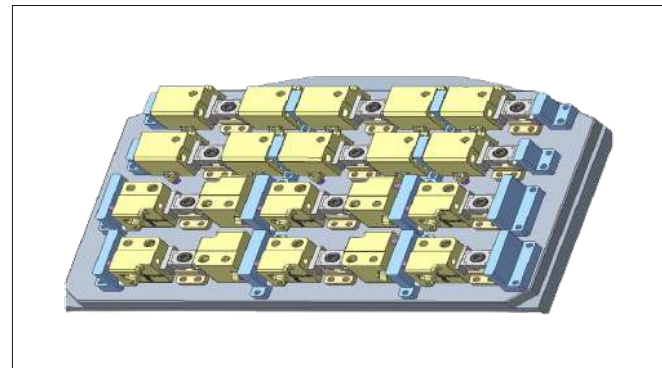
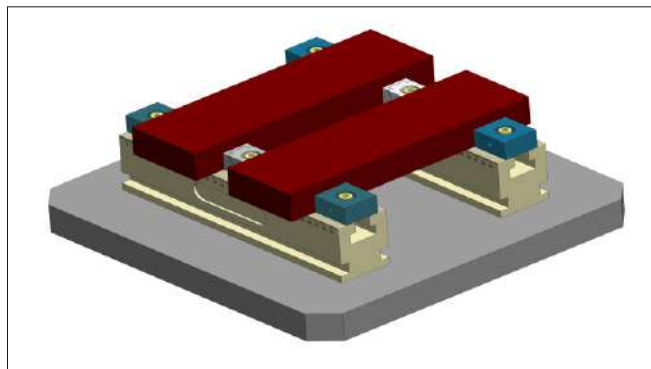
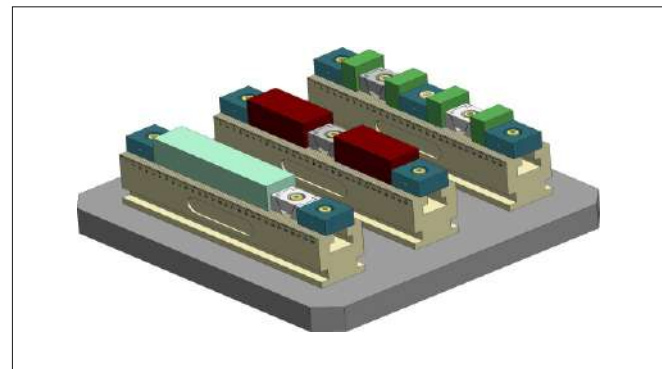
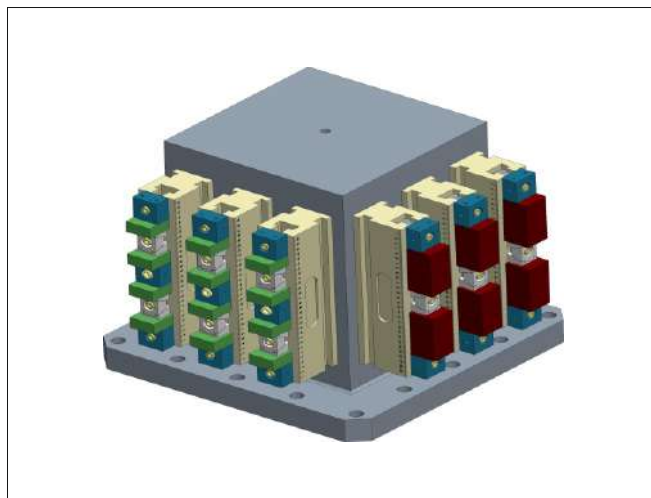
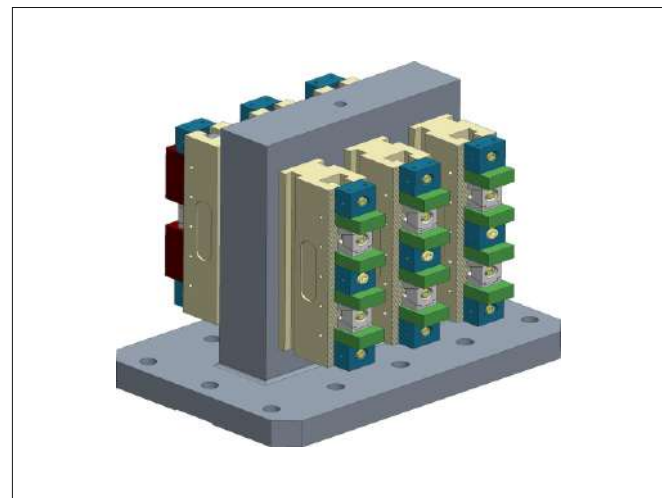



## BPP/RT



### Rectangular Base Plate - Plane

- Material : Cast iron GG30(DIN) / C45
- Heat Treated (Normalised)
- Features :
  - Can be special ordered with any size
  - Thickness available from 35mm to 50mm
- Application : vertical machining center

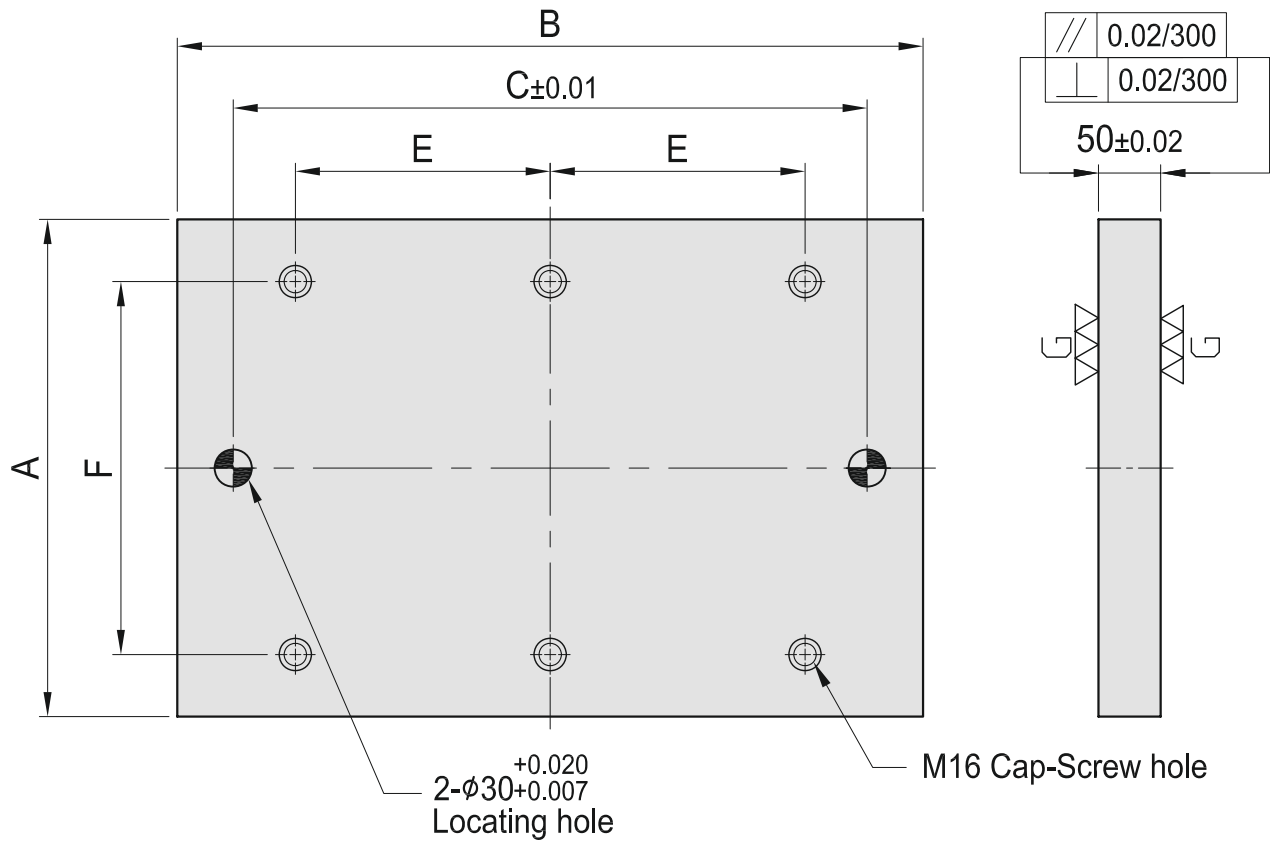

MODEL NO.	A	B	C	E	F	kg
BPP/RT/400600	400	600	-	-	-	88
BPP/RT/500600	500					106
BPP/RT/400800	400	800	-	-	-	113
BPP/RT/450900	450	900				142
BPP/RT/5001000	500	1000	-	-	-	176

NOTE: C.E.F. Values as per customer's requirement



### Rectangular Base Plate - Grid Hole

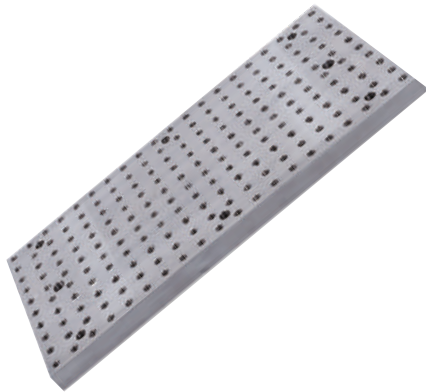

- Material : Cast iron GG30(DIN) / C45
- Heat Treated (Normalised)
- Features :
  - Alignment bushing
  - Threaded insert
  - MTP hole spacing :  $50 \pm 0.02$
  - Grid holes available in M12 & M16
  - Easily adapts to standardized jig components
- Application : Vertical machining center

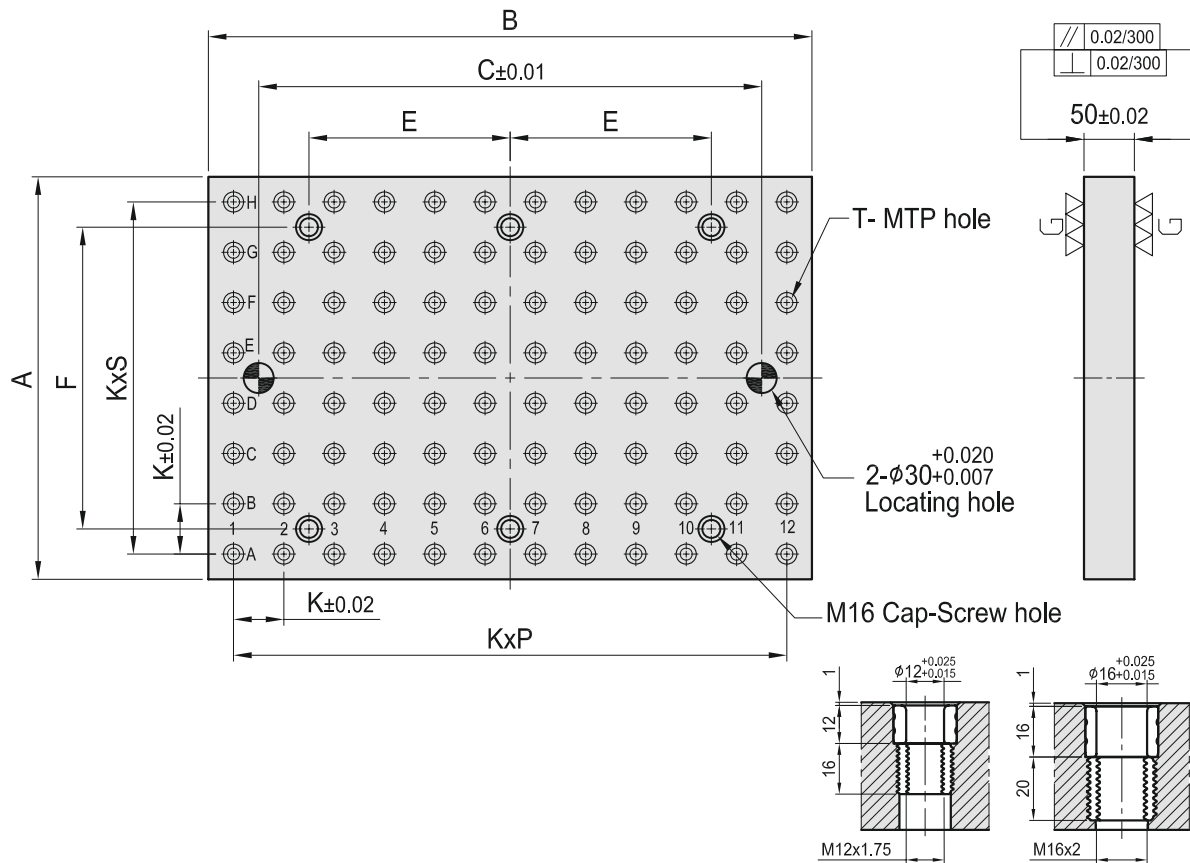

Figure T

MODEL NO.	A	B	C	E	F	K	P	S	MTP	kg
BPG/RT/400600	400	600	-	-	-	50	11	7	96	90
BPG/RT/500600	500							9	120	112
BPG/RT/400800	400	800	-	-	-	50	15	7	128	109
BPG/RT/450900	450						17	8	158	138
BPG/RT/5001000	500	1000	-	-	-	50	19	9	200	165

NOTE: C.E.F. Values as per customer's requirement



# BPT/RT

Rectangular Base Plate



## Rectangular Base Plate - T-slot

- Material : Cast iron GG30(DIN) / C45
- Heat Treated (Normalised)
- Features :
  - T-slots available in 14mm & 18mm (D)
  - T-slots running in 2 directions
  - Easily adapts to standardized jig components
- Application : Vertical machining center

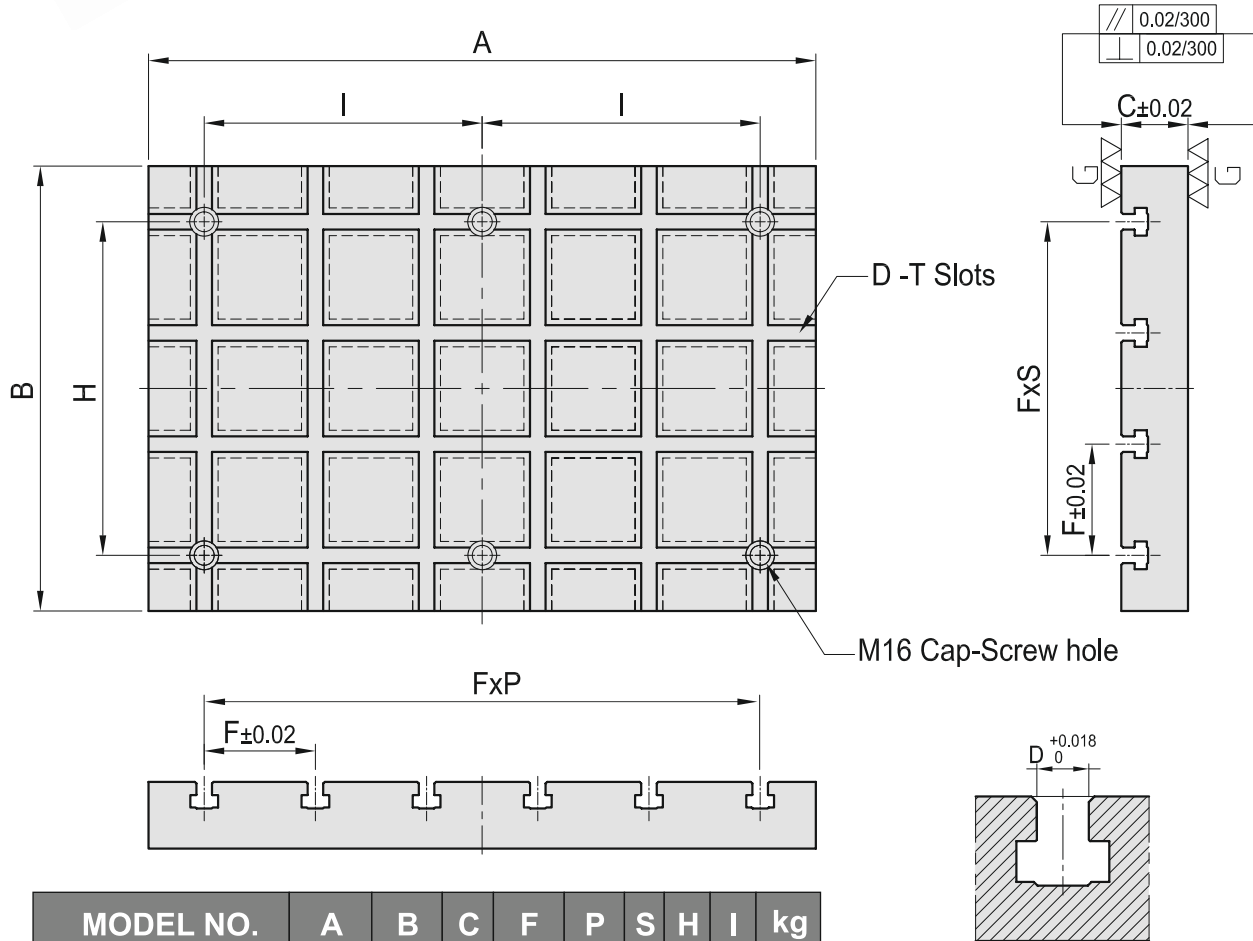

MODEL NO.	A	B	C	F	P	S	H	I	kg
BPT/RT/400600	600	400	60	100	5	3	-	-	92
BPT/RT/500600		500				4			115
BPT/RT/400800	800	400	60	100	7	3	-	-	117
BPT/RT/450900	900	450			8				168
BPT/RT/5001000	1000	500	60	100	9	4	-	-	198

Note : H and I Value as per Customer Requirement



# BPP/SQ

## Square Base Plate - Plane



- Material : Cast iron GG30(DIN) / C45
- Heat Treated (Normalised)
- Features :
  - Can be special ordered with any size
  - MTP hole
  - Thickness available from 35mm to 50mm
- Application : Horizontal machining center

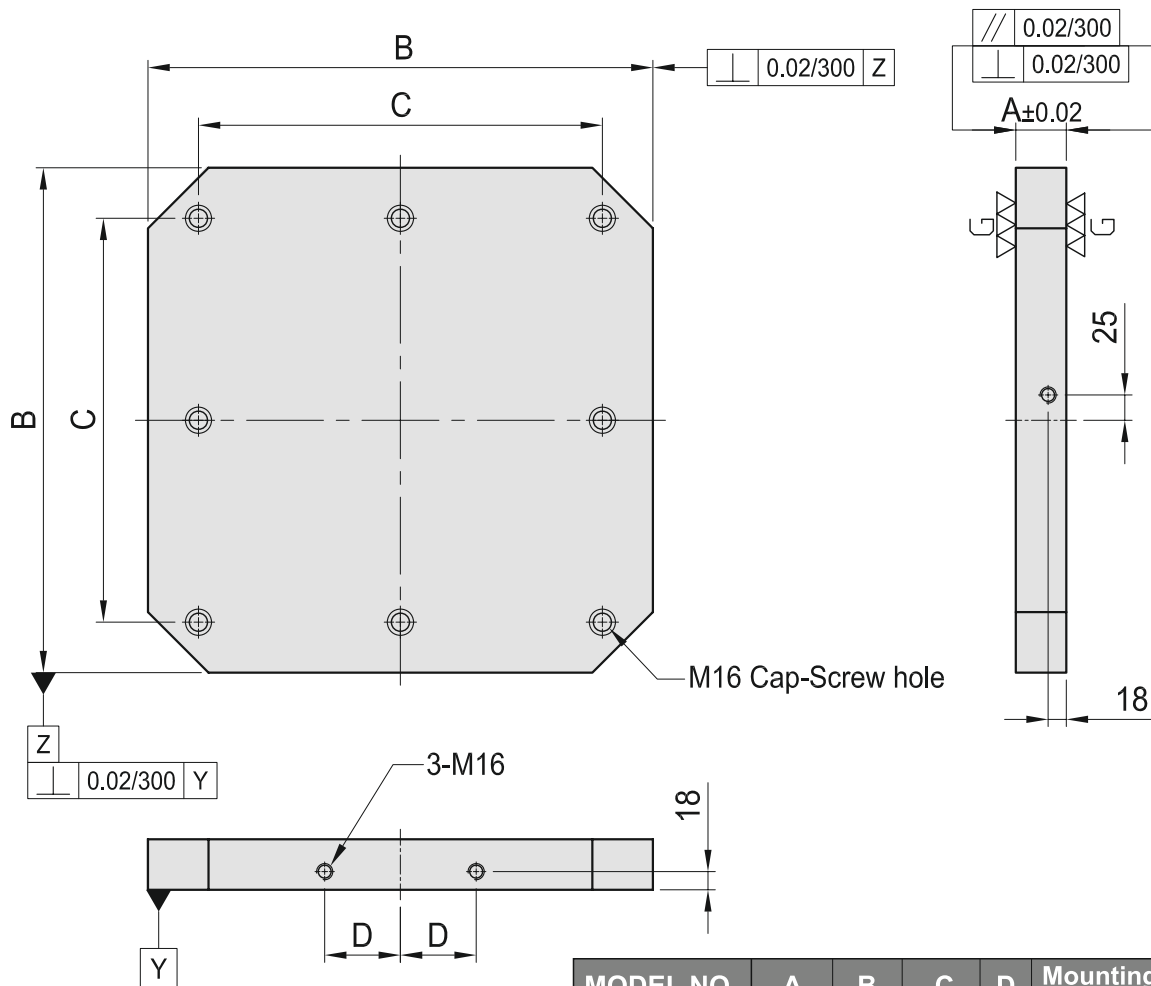

MODEL NO.	A	B	C	D	Mounting holes	kg
BPP/SQ/400	50	400	320	55	4	57
BPP/SQ/500	50	500	400	75	8	88
BPP/SQ/630	50	630	500	100	8	140
BPP/SQ/800	50	800	640	135	8	225

Note : C Value as per Customer Requirement



# BPT/SQ

Square Base Plate

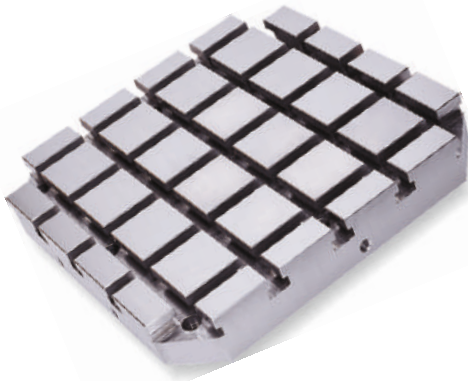

## Square Base Plate - T-slot

- Material: Cast iron GG30(DIN) / C45
- Heat Treated (Normalised)
- Features :
  - T-slots available in 14 & 18 (D)
  - T-slots running in 2 directions
  - Easily adapts to standardized jig components
- Application: Horizontal machining center

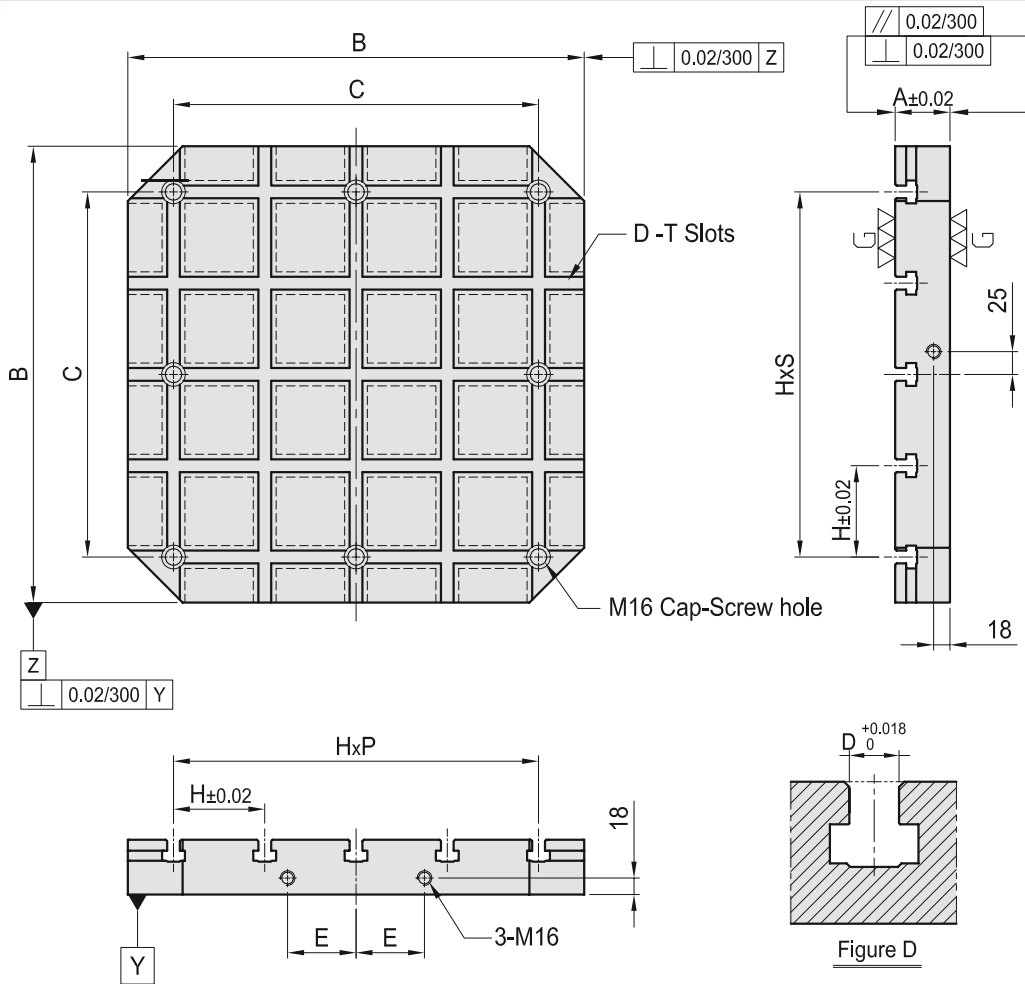

MODEL NO.	A	B	C	E	H	P	S	Mounting holes	kg
BPT/SQ/400	60	400	320	55	80	4	4	4	56
BPT/SQ/500		500	400	75	100			8	90
BPT/SQ/630	75	630	500	100	125	4	4	8	150
BPT/SQ/800		800	640	135	160				230

Note : C Value as per Customer Requirement



# BPG/SQ

## Square Base Plate - Grid Hole



- Material : Cast iron GG30(DIN) / C45
- Heat Treated (Normalised)
- Features :
  - Alignment bushing
  - Threaded insert
  - MTP hole spacing :  $50 \pm 0.02$
  - Grid holes available in M12 & M16
  - Easily adapts to standardized jig components
- Application : Horizontal machining center

Square Base Plate

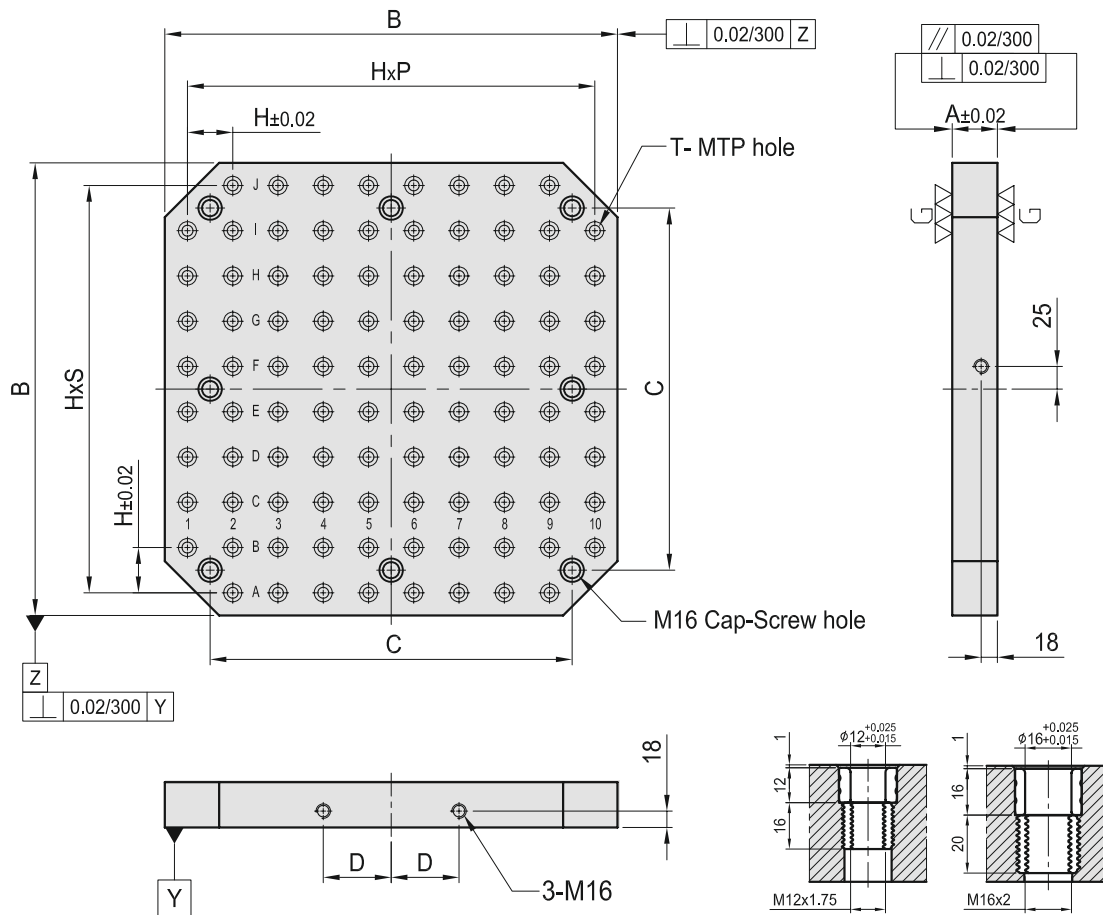

Figure T

MODEL NO.	A	B	C	E	H	P	S	MTP	Mounting holes	kg
BPG/SQ/400	50	400	320	55	50	7	7	59	4	54
BPG/SQ/500		500	400	75		9	9	93	8	83
BPG/SQ/630	50	630	500	100	50	11	11	139	8	135
BPG/SQ/800		800	640	135		15	15	237		206

Note : C Value as per Customer Requirement



# BPP/R

## Round Base Plate-plane



- Material: Cast iron GG30(DIN) / C45
- Heat Treated (Normalised)
- Features:
  - Can be special ordered with any size
  - Thickness available from 35mm to 50mm
- Application: Nc rotary table or Indexer

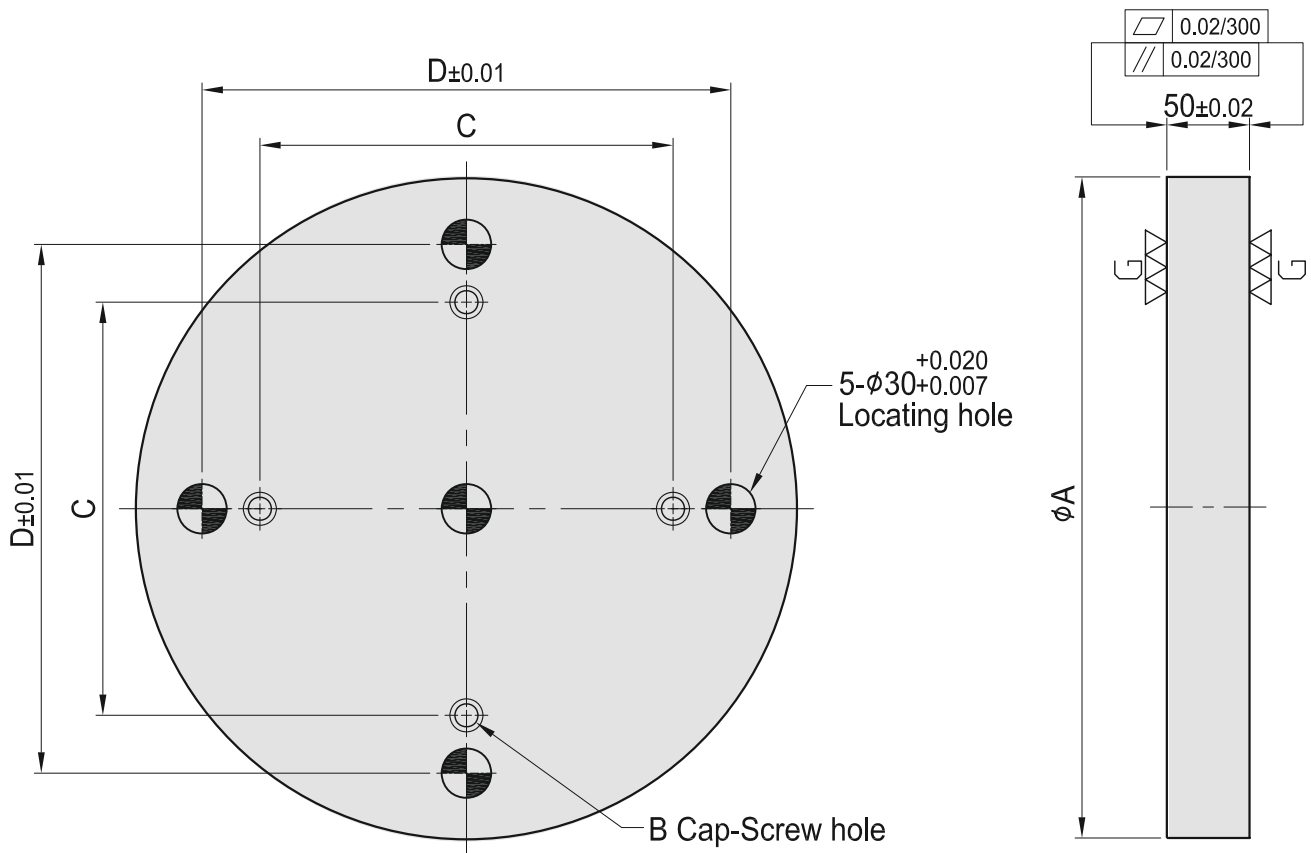

MODEL NO.	A	B	C	D	kg
BPP/R/D300	300	M12	150	220	25
BPP/R/D400	400		250	320	40
BPP/R/D500	500	M16	300	400	65
BPP/R/D600	600		400	500	95



### Round Base Plate - Grid Hole



- Material : Cast iron GG30(DIN) / C45
- Heat Treated (Normalised)
- Features :
  - Alignment bushing
  - Threaded insert
  - MTP hole spacing :  $50 \pm 0.02$
  - Grid holes available in M12 & M16
  - Easily adapts to standardized jig components
- Application : NC rotary table or indexer

Round Base Plate

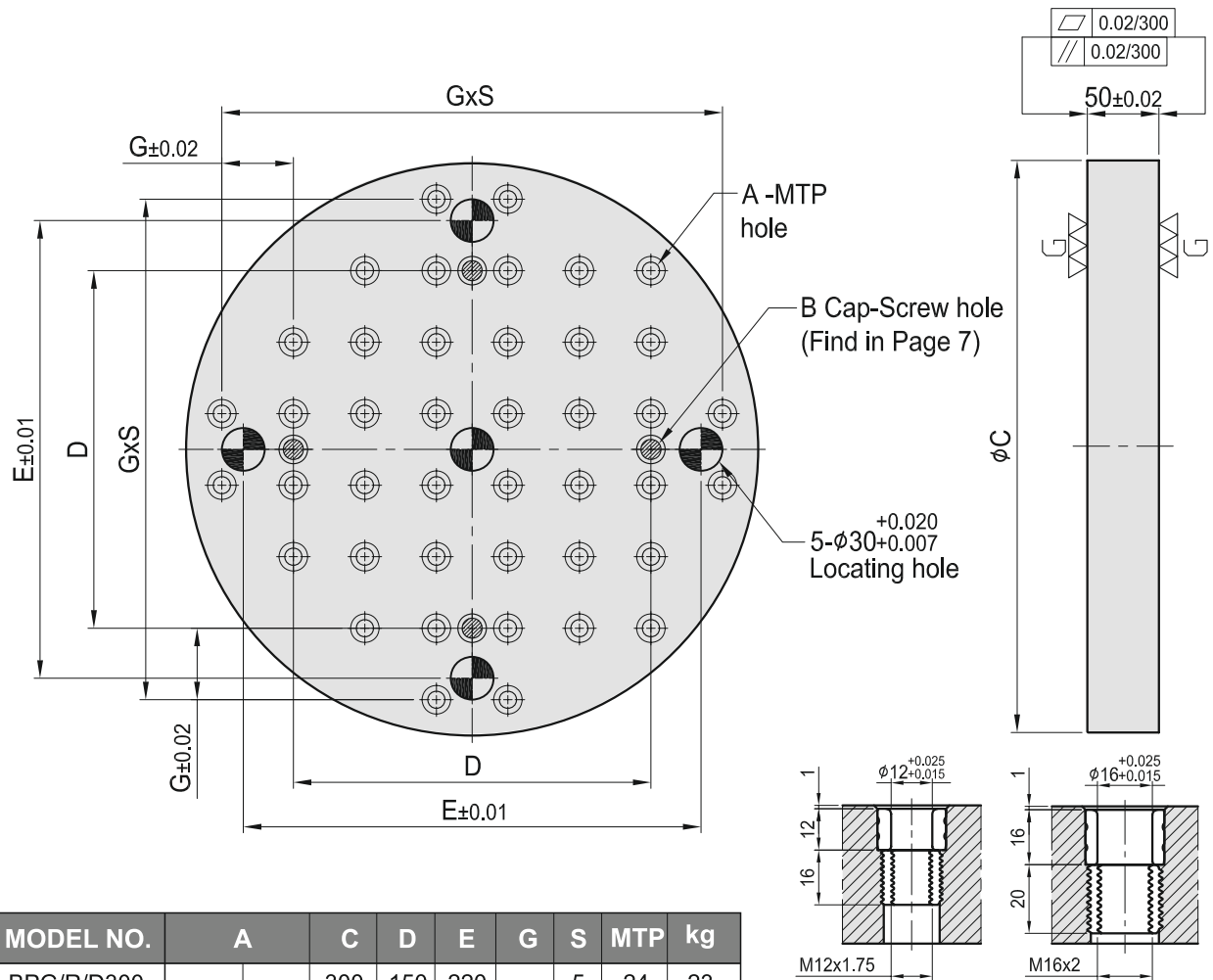

MODEL NO.	A	C	D	E	G	S	MTP	kg	
BPG/R/D300	Ø12	M12	300	150	220	50	5	24	23
BPG/R/D400			400	250	320		7	44	42
BPG/R/D500	Ø12	M12	500	300	400	50	9	68	70
BPG/R/D600			600	400	500		11	96	98
BPG/R/D500	Ø16	M16	500	300	400	50	9	68	68
BPG/R/D600			600	400	500		11	96	95

Figure A



# BPT/R

Round Base Plate

## Round Base Plate - T-slot

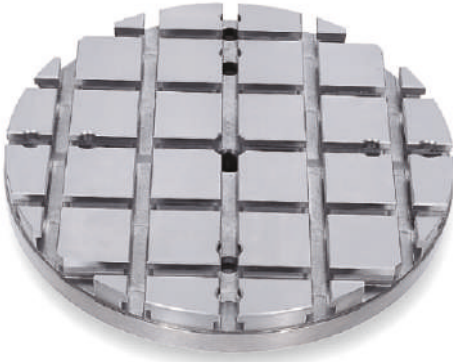

- Material: Cast iron GG30(DIN)/C45
- Heat Treated (Normalised)
- Features:
  - T-slots available in 14 & 18 (J)
  - T-slots running in 2 directions
  - Easily adapts to standardized jig components
- Application : NC rotary table or indexer

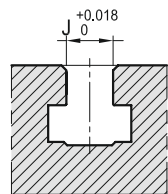
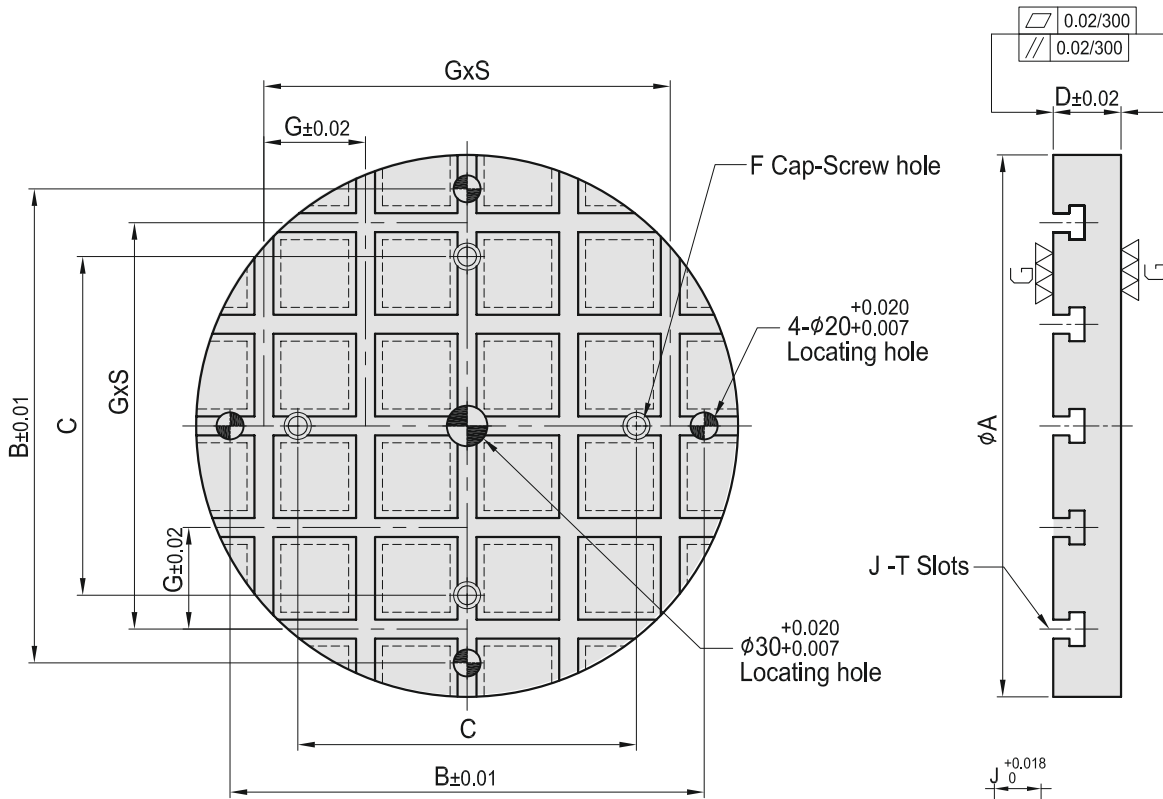

Figure J

MODEL NO.	A	B	C	D	F	G	S	kg
BPT/R/D300	300	250	150	50	M12	75	2	22
BPT/R/D400	400	350	250				4	36
BPT/R/D500	500	450	300	65	M16	100	4	74
BPT/R/D600	600	550	400				4	110



# TSP/SQ



## Square Clamping Column - Plane

- Material: Cast iron GG30(DIN)
- Heat Treated (Normalised)
- Features:
  - Fully machined on all sides
  - Side edge locating holes on base
  - Top cover to keep out chips and coolant
- Eye bolt for lifting
- Application: Horizontal machining center

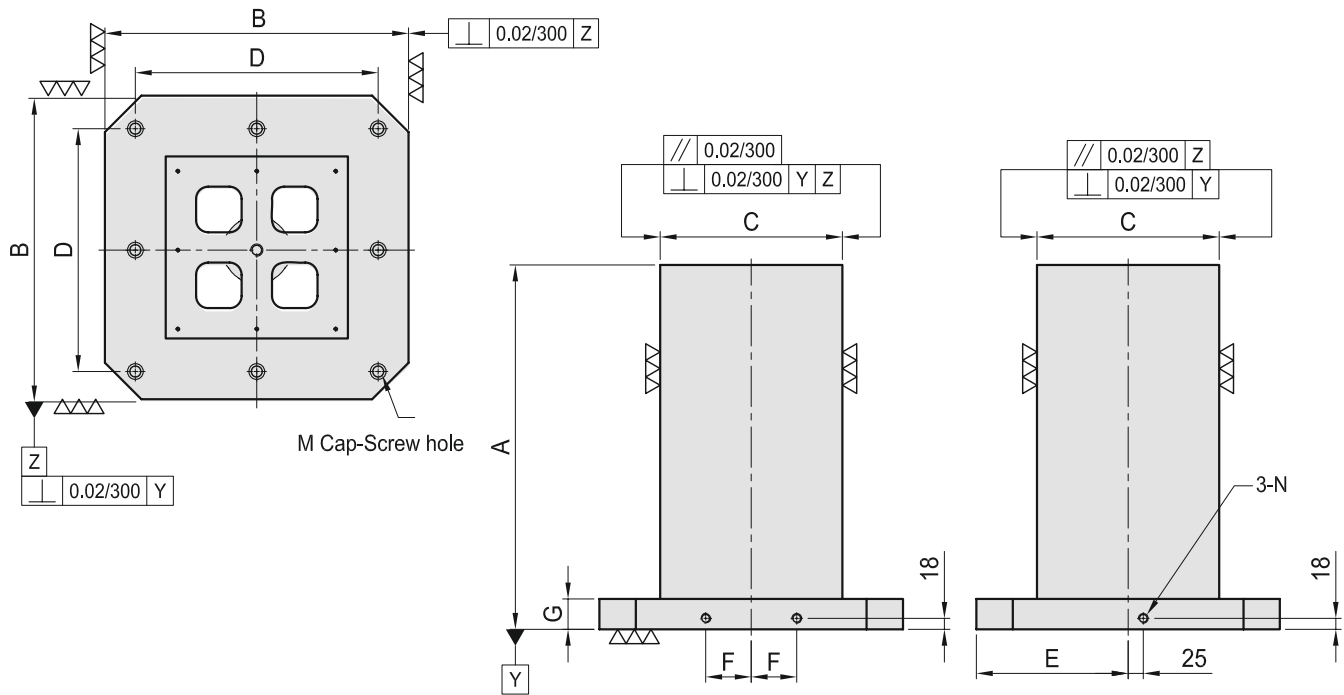

MODEL NO.	A	B	C	D	E	F	G	M	N	Mounting holes	Weight in kg
											Cast Iron
TSP/SQ/150	500	300	150	250	150	40	50	M12	M12	4	90
TSP/SQ/250	500	400	250	320	200	55	50	M16	M16	4	160
	650										210
TSP/SQ/300	600	500	300	400	250	75	50	M16	M16	8	250
TSP/SQ/350	700	630	350	500	315	100	50	M16	M16	8	400



# TSG/SQ

## Square Clamping Column - Grid Hole



- Material : Cast iron GG30(DIN)
- Heat Treated (Normalised)
- Features :
  - Alignment bushing
  - Threaded inserts
  - MTP hole spacing :  $50 \pm 0.02$
  - Grid holes available in M12 & M16
  - Eye bolt & top cover included
  - Easily adapts to standardized jig components
- Application : Horizontal machining center

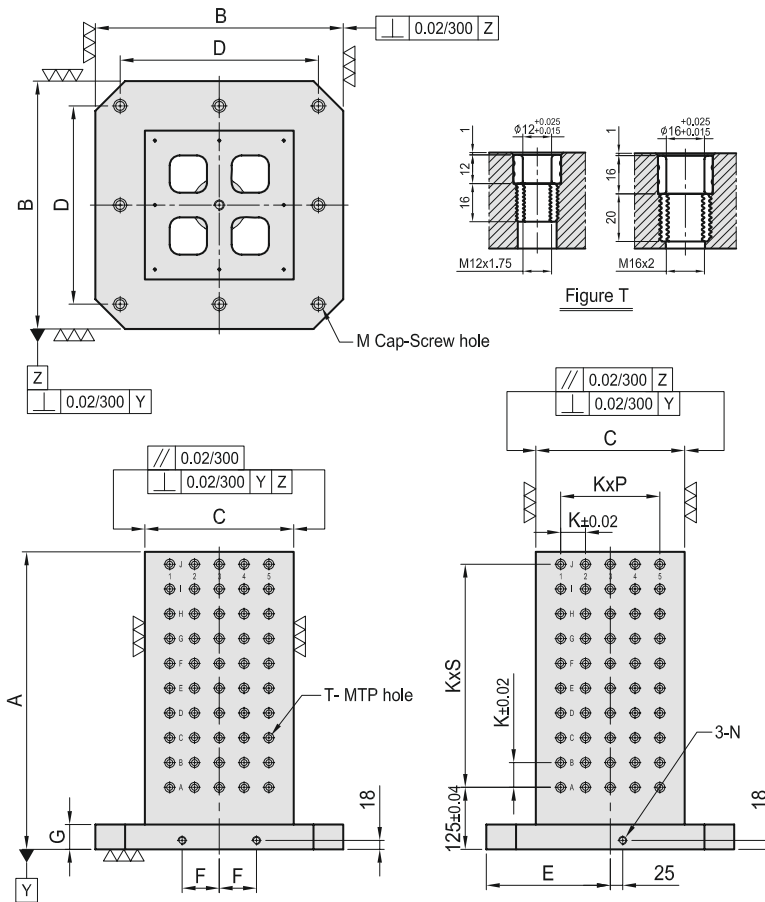

MODEL NO.	A	B	C	D	E	F	G	K	P	S	M	N	MTP	Mounting holes	Weight in kg
															Cast Iron
TSG/SQ/150	500	300	150	250	150	40	50	50	1	7	M12	M12	64	4	90
TSG/SQ/250	500	400	250	320	200	55	50	50	3	7	M16	M16	128	4	155
	650														200
TSG/SQ/300	600	500	300	400	250	75	50	50	4	9	M16	M16	200	8	240
TSG/SQ/350	700	630	350	500	315	100	50	50	5	11	M16	M16	288	8	360



### Square Clamping Column - T-slot



- Material: cast iron GG30(DIN)
- Heat treated (Normalized)
- Features :
  - T-slot available in 14 & 18 (J)
  - T-slot running horizontally
  - Key-way running vertically
  - Easily adapts to standardized jig components
  - Eye bolt & top cover included
- Application: Horizontal machining center

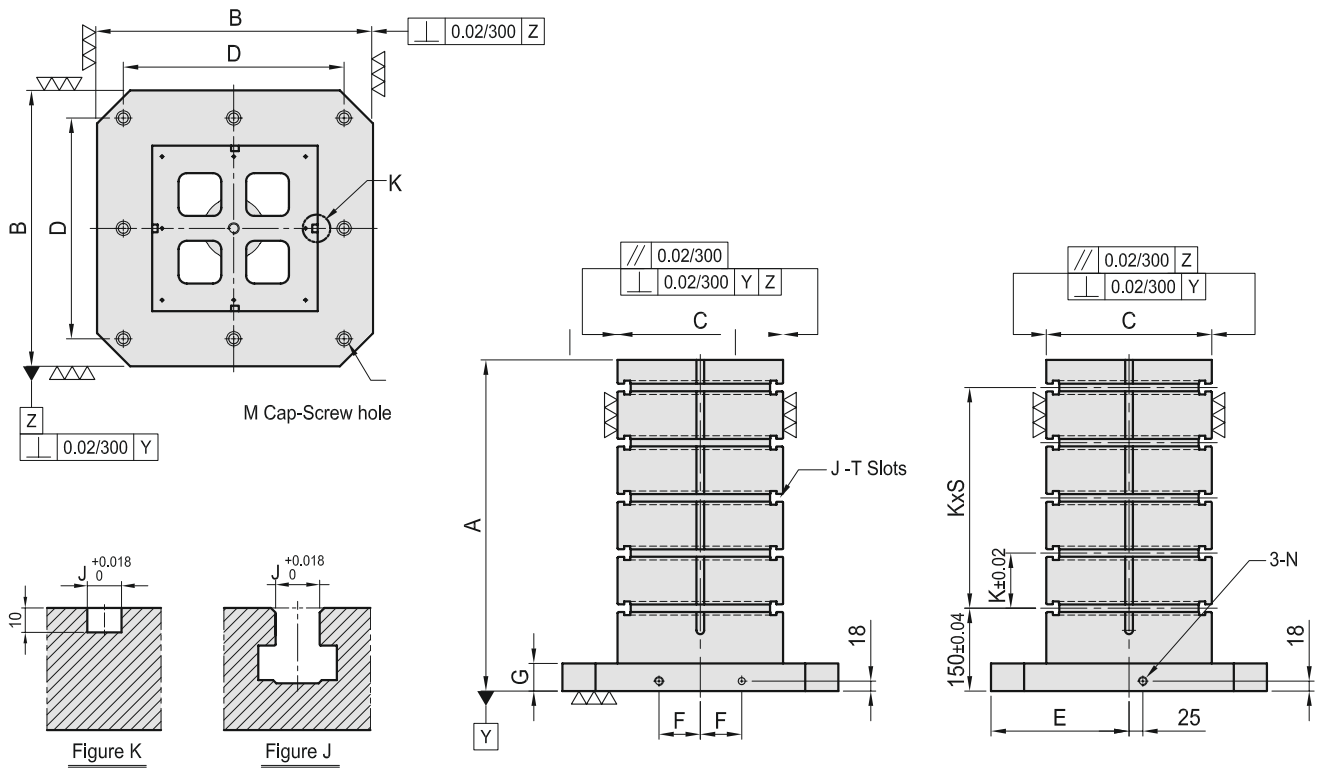

MODEL NO.	A	B	C	D	E	F	G	M	N	K	S	Mounting holes	Weight in kg
													Cast Iron
TST/SQ/250	500	400	250	320	200	55	50	M16	M16	100	3	4	160
	650												210
TST/SQ/300	600	500	300	400	250	75	50	M16	M16	100	4	8	270
TST/SQ/350	700	630	350	500	315	100	50	M16	M16	125	4	8	375



# TSP/RT

## Double Sided Clamping Column - Plane



- Material : cast iron GG30(DIN)
- Heat treated (Normalized)
- Features :
  - Fully machined on all sides.
  - Side edge locating holes on base.
  - Top cover to keep out chips and coolant
  - Eye bolt for lifting.
- Application : Horizontal machining center

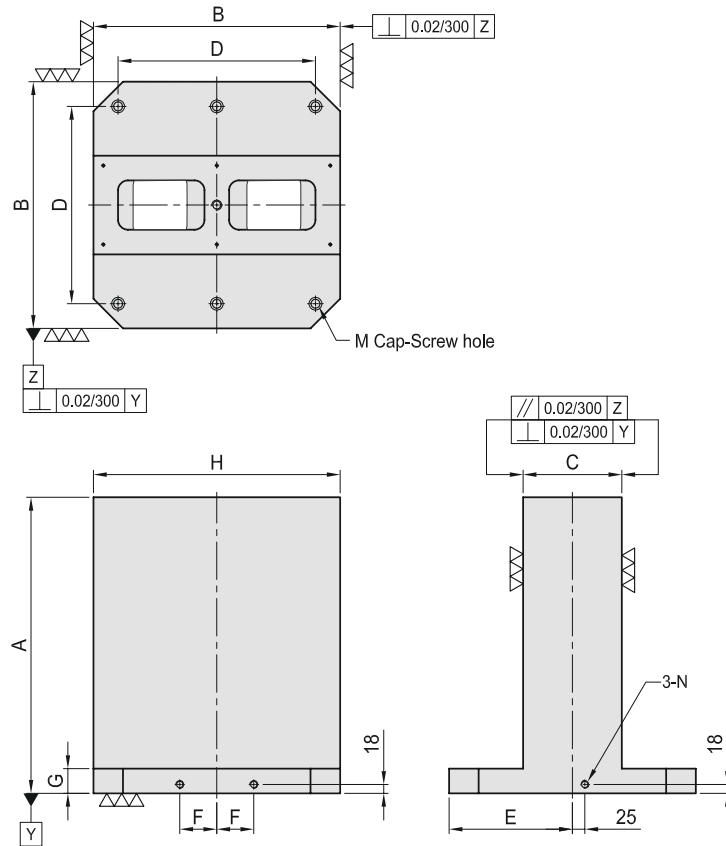

MODEL NO.	A	B	C	D	E	F	G	H	M	N	Mounting holes	Weight in kg
												Cast Iron
TSP/RT/80300	500	300	80	250	150	40	50	300	M12	M12	4	115
TSP/RT/150400	500	400	150	320	200	55	50	400	M16	M16	4	170
	650											215
TSP/RT/200500	600	500	200	400	250	75	50	500	M16	M16	6	270
TSP/RT/250630	700	630	250	500	315	100	50	630	M16	M16	6	445



# TSG/RT

## Double Sided Clamping Column - Grid Hole



- Material : cast iron GG30(DIN)
- Heat treated (Normalized)
- Features :
  - Alignment bushing
  - Threaded insert
  - MTP hole spacing :  $50 +0.02$
  - Grid holes available in M12 & M16
  - Easily adapts to standardized jig components
  - Eye bolt & top cover included.
- Application : Horizontally machining center.

Double Sided Clamping Column

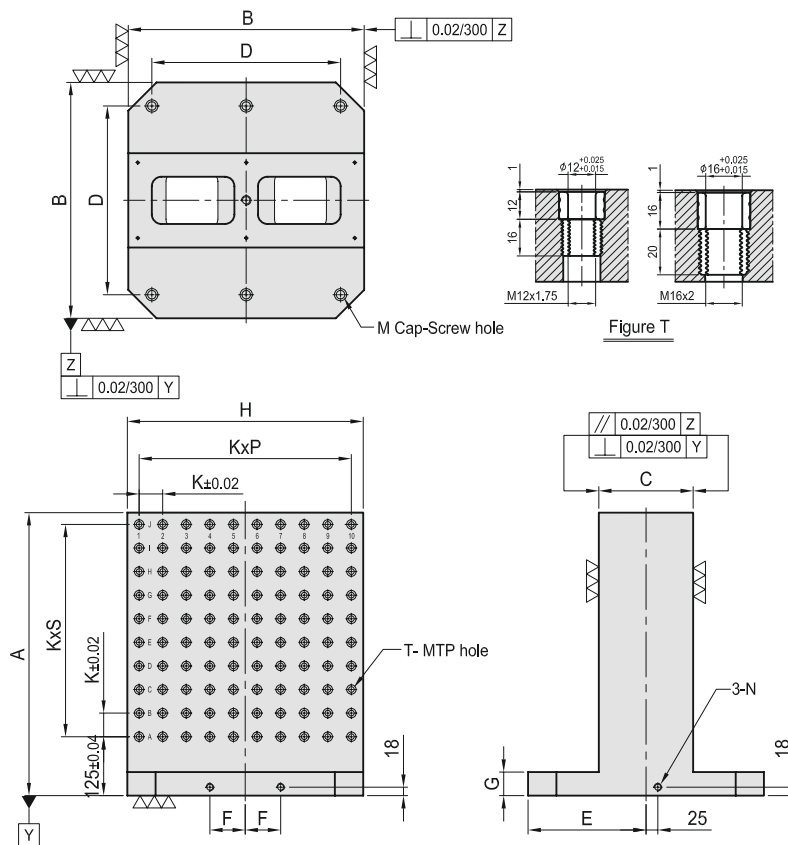

MODEL NO.	A	B	C	D	E	F	G	H	K	P	S	M	N	MTP	Mounting holes	Weight in kg
																Cast Iron
TSG/RT/80300	500	300	80	250	150	40	50	300	50	5	7	M12	M12	96	4	110
TSG/RT/150400	500 650	400	150	320	200	55	50	400	50	3	7	M16	M16	128 176	4	165
TSG/RT/200500	600	500	200	400	250	75	50	500	50	4	9	M16	M16	200	6	265
TSG/RT/250630	700	630	250	500	315	100	50	630	50	5	11	M16	M16	288	6	435



# TST/RT

Double Sided Clamping Column



## Double Sided Clamping Column - T-slot

- Material: Cast iron GG30(DIN)
- Heat treated (Normalized)
- Features :
  - T-slot available in 14 & 18 (J)
  - T-slot running horizontally
  - Key-way running vertically
  - Easily adapts to standardized jig components
  - Eye bolt & top cover included
- Application: Horizontal machining center

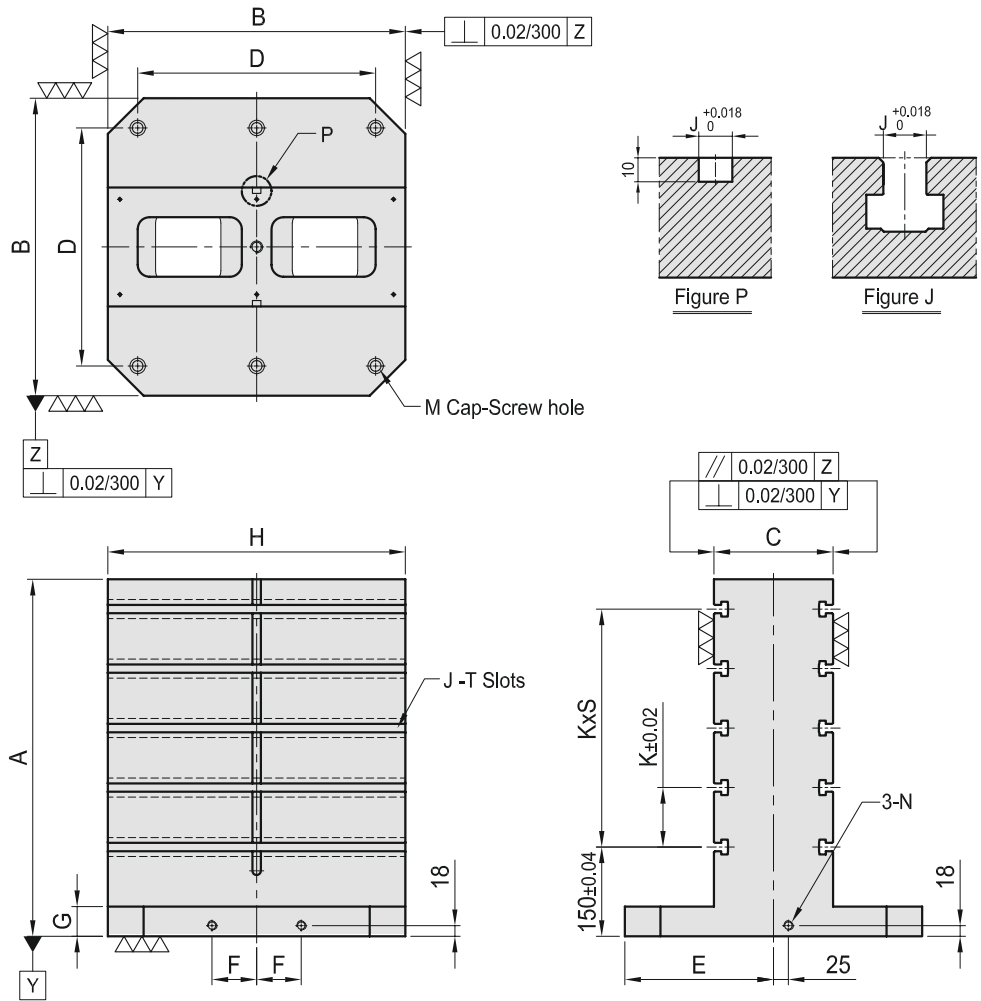

MODEL NO.	A	B	C	D	E	F	G	M	N	H	K	S	Mounting holes	Weight in kg	
														Cast Iron	
TST/RT/150400	500	400	150	320	200	55	50	M16	M16	400	100	3	4	170	
	650													220	
TST/RT/200500	600	500	200	400	250	75	50	M16	M16	500	100	4	6	290	
TST/RT/250630	700	630	250	500	315	100	50	M16	M16	630	125	4	6	440	



## Sub-Table

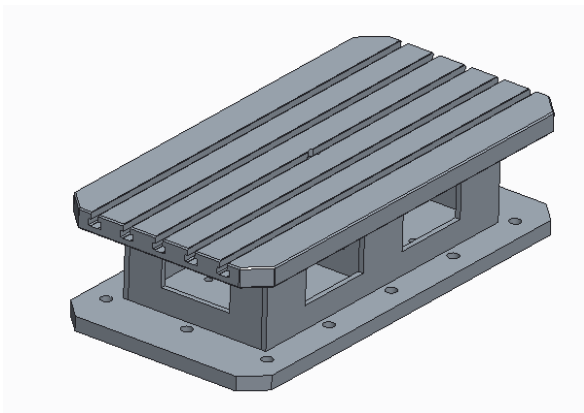

- Material: Cast iron GG30(DIN)
- Heat Treated & Normalised.
- Features:
  - Ready to accept a hole pattern
  - T-slot pattern for your special jig.
  - Available in custom sizes
- Applications :
  - Vertical machine centers
  - Horizontal machine centers
  - Special purpose machines.

### Applications :





# SPECIFICATIONS

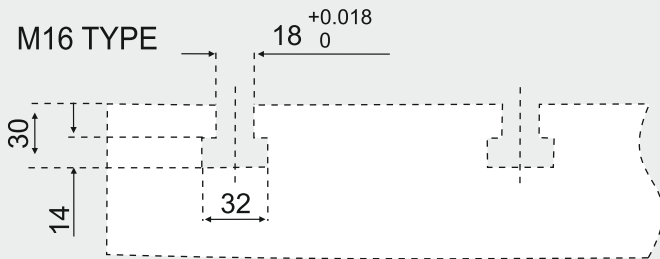
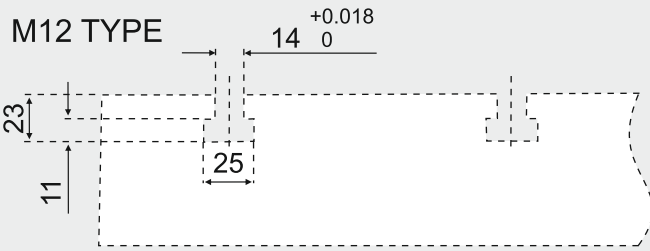
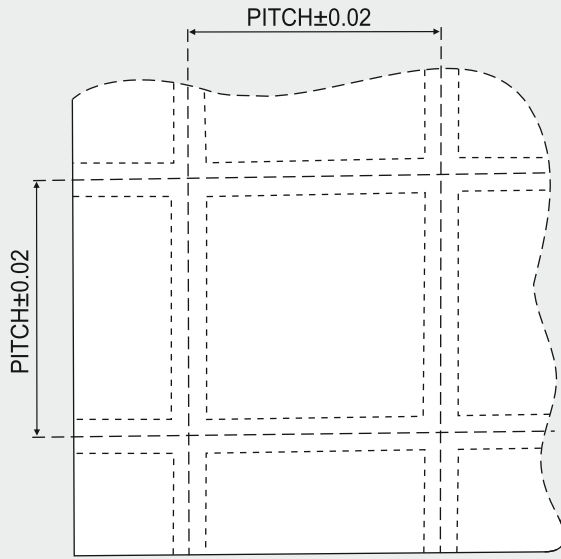

M12 Cap-Screw hole

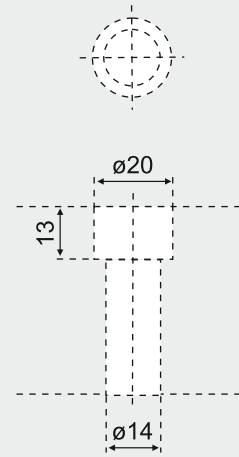

M16 Cap-Screw hole

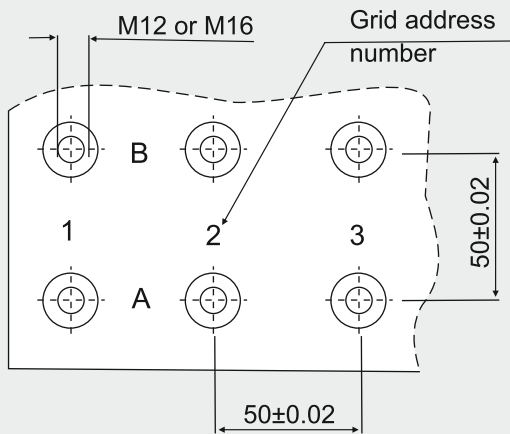
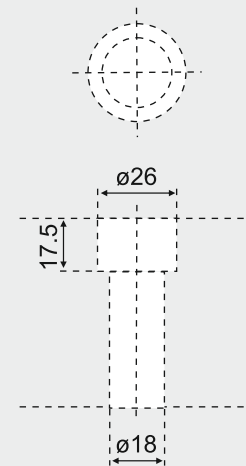

ø12 MTP hole

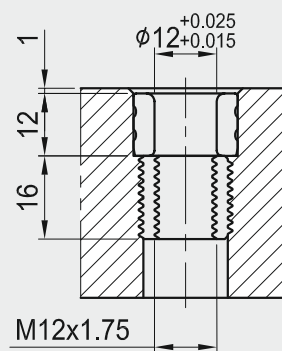

ø16 MTP hole

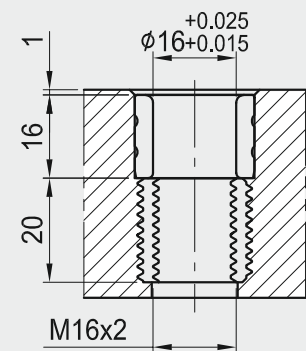



### Threaded spindle

Spindle without power intensification



### Mechanical power intensification

Purely mechanical power intensifier



### Gripper spindle

Spindle with mechanical power intensification for clamping and machining unmachined workpieces



### Fully enclosed spindle

Scraper provides protection against dirt - enhanced functional reliability, optimal chip protection and minimal cleaning. Nitrated spindle !



### Power preset

Spindle power can be preset in increments



### Horizontal installation

Suitable for vertical machining centres



### Click system

Quick change system for false jaws and parallels



MANUFACTURED BY



Productivity Improvement Solutions

## AHIRE MACHINE TOOLS PVT. LTD.

Corp. off. D-1/18, MIDC Ambad, Nashik-422010, India.

Works: Phoenix industrial park, shed no. E, gate no. 47, mauje wasali, Nashik-422007

M: (+91) 9922448079 / (+91) 9130099422 / (+91) 9096003430 / (+91) 9922923060

[www.amtplindia.com](http://www.amtplindia.com) | [sales@amtplindia.com](mailto:sales@amtplindia.com)

Manufactured under license form ALLMATIC-JAKOB Spansysteme GmbH, Germany

[www.allmatic.de](http://www.allmatic.de)