



DB/DC-23A
DB/DC-28A

Machine type: AMT _____

Machine Serial no.: _____

Ahire Machine Tools Pvt.Ltd.

D1/18, MIDC Ambad Nashik.

422010, Maharashtra, India.

Email: sales@amtplindia.com

Website: www.amtplindia.com

Sales

Phone: +91 9130099422

+91 9922413270

+91 9922448079



INDIA www.amtplindia.com

FRONT PAGE	I
CONTENT	II
WARRENTY	III
TEST CHART	1-3
TECHNICAL DATA	
DB/DC-23/28A.....	4
SAFETY INSTRUCTION	5-8
UNPACKING & INSTALLATION	
TRANSPORTING & UNPACKING.....	9
INSTALLATION SITE.....	9
MACHINE MOUNTING & TOOL HOLDING.....	10
SPEED CHART.....	11
ELECTRICAL INSTALLATION.....	12
PROGRAMING	13-17
CHECK LIST FOR STARTUP	18
OPERATION	
MOUNTING & REMOVING TOOL.....	19-20
ADJUST DISTANCE BETWEEN DRILLING BIT AND WORKPIECE.....	21
TYPES OF OPERATION.....	22
MAINTENANCE	
LUBRICATION INSTRUCTIONS.....	23-25
BELT REPLACE.....	26
TROUBLESHOOTING	
MALFUNCTION TABLE.....	27-28
REPLACEMENT	
REPLACEMENT OF PARTS.....	29
APPENDIX	
MECHANICAL DIAGRAM.....	30
ELECTRICAL DRAWINGS.....	31-32

WARRANTY

The machine is warranted against poor material / workman ship for a period of fifteen months from the date of dispatch OR twelve months from the date of installation, whichever is earlier.

(On single shift usage of machine) (For std. M/CS separate commissioning is not done)

If any material / manufacturing defects is/are detected and brought to our notice during this period, we guarantee to repair and / or replace these defective part/s FREE – OF – COST.

(Subject to receipt of such item/s, sent prepaid to our factory for our inspection / evaluation)

CAUTION

All consumable Electric / Electronic / Pneumatic / Hydraulic / Mechanical items such as ...

A.C / D.C. coils, HRC / Glass fuses, piston and valve seals, rubber parts, semi – conductor devices, wear pads, guide bushes etc... are EXCLUDED from this warranty clause.

This warranty is also NOT applicable for any parts, equipment or items, which has / have inherently shorter life than above mentioned warranty period.

Please note, our warranty will be valid ONLY if, machine / equipment is used / operated as per guidelines of instruction manual and necessary preventative maintenance schedule is maintained.

Evaluation of defects / parts done by our technical team will be final.



IMPORTANT INFO

The operating manual and various pictures / diagrams / circuits shown there in are exclusive property of M/S AHIRE MACHINE TOOLS PVT. LTD., all rights are reserved.

Unauthorized duplication and / or use, in any forms is not permitted, unless confirmed with us.

DO NOT OVER LOAD AND / OR TAMPER THE MACHINE / EQUIPMENT!





ENSURE OPERATOR SAFETY. DO NOT OPERATE MACHINE WITH GUARDS REMOVED.



FIRM+MULTIPLE EARTHING CONNECTION OF MACHINE / EQUIPMENT IS MANDATO

TECHNICAL DETAILS

Description	DB/DC-23A	DB/DC-28A
Standard Drilling capacity in mild steel	:23 mm	:28 mm
Direct Drilling capacity in mild steel	:15 mm	:20 mm
Spindle taper	:MT 2	:MT 3
Spindle Travel	:120 mm	:120 mm
Spindle to column	:240 mm	:240 mm
Spindle to Work table	:308/600 mm	:308/600 mm
Spindle to Base Plate	:600/1170 mm	:600/1170 mm
Table surface	:240x240 mm	:240 x240 mm
T-slot width	:12 mm	:12 mm
Column Diameter	:80 mm	:80 mm
Total height	:1130/1700 mm	:1130/1700mm
Weight	:165/180 kg	:165/180 kg
Induction Motor	:1 Hp	:2 Hp
8-Spindle Speed	:112 – 2800 rpm	:112 -2800 rpm
Operating voltage	:415VAC	:415VAC
Frequency	:50HZ	:50Hz
Power Fuse	:5Amp	:5Amp

SAFETY INSTRUCTION

	<ul style="list-style-type: none">• Wear eye Protection.
	<ul style="list-style-type: none">• Tie long hair together.
	<ul style="list-style-type: none">• Wear hairnet if hair is very long.
	<ul style="list-style-type: none">• Wear safety Shoe/Boots.

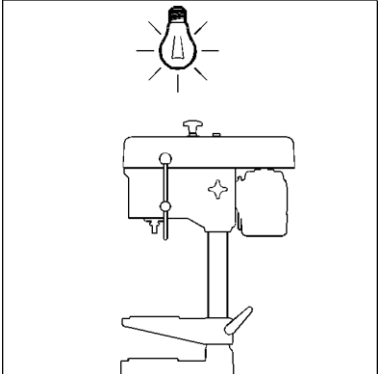
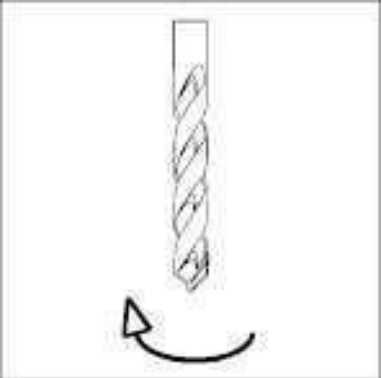
	<ul style="list-style-type: none">• Remove jewelry prior to commencing work.
	<ul style="list-style-type: none">• Do not touches spindle in motion!
	<ul style="list-style-type: none">• Ensure sufficient lighting• Operating elements must be easily accessible.
	<ul style="list-style-type: none">• Rotation right-hand.

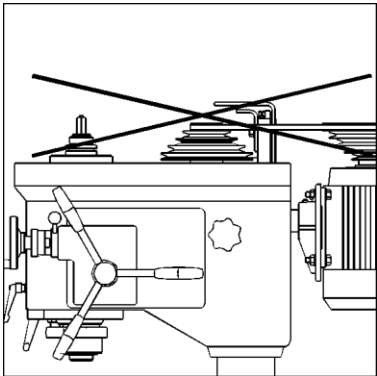
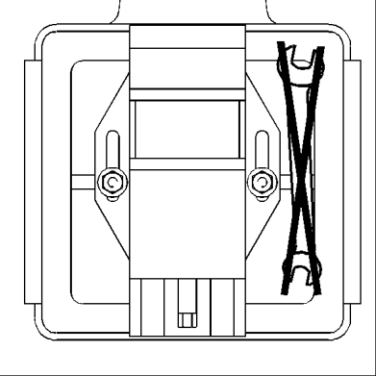
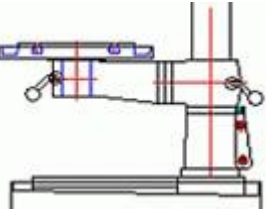
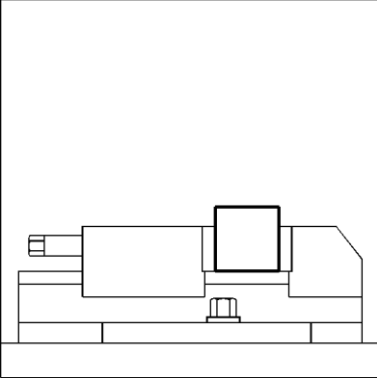
	<ul style="list-style-type: none">• Never switch on machine without protective hood.
	<ul style="list-style-type: none">• Do not deposit tools or measuring equipment in work area.
	<ul style="list-style-type: none">• Adjust table clamp prior to commencing work.
	<ul style="list-style-type: none">• Secure component.

	<ul style="list-style-type: none"> • Feed lever returns automatically.
	<ul style="list-style-type: none"> • While maintenance / servicing time please turn off the MCB switch which is placed in panel box.
	<ul style="list-style-type: none"> • Remove drift prior to switching machine ON.
	<ul style="list-style-type: none"> • Never carry out tool change by driving up the quill with drill drift • Only strike at drill drift with fiber hammer. • Drill to maximal \varnothing employs 20 mm for continuous operation. <p>  Component destruction. </p>

UNPACKING & INSTALLATION

Unpacking and transporting:

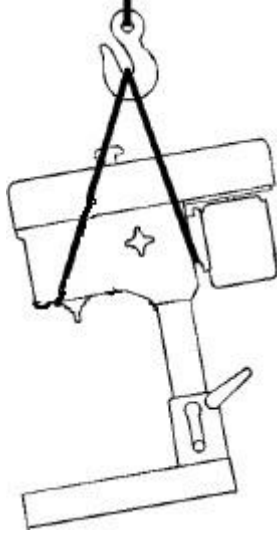

Installation site:

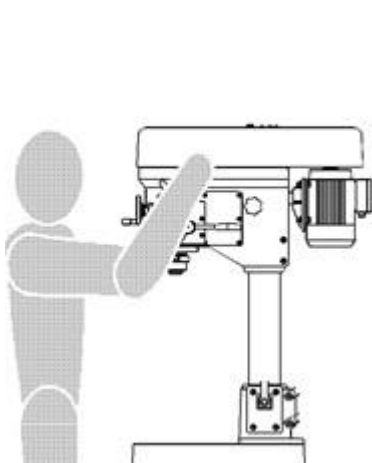

- Compare the items on the delivery bill with the actual delivery.
- Observe the safety regulations for moving loads.
- Unless otherwise specified, Machine is supplied in commercial, non-reusable Wooden Box Packing.
- Ensure that Box is kept in Up-right position, **↑↑** as marked, on Box, before unpacking.
- Due care should be taken while un-loading.
- For transporting use a crane. Fasten the ropes as shown in the picture. Land it carefully on assigned position of the floor.
- Before tying rope remove delicate parts like handles and which is made by non-metallic material.
- All service components must be within easy reach
- Watch for horizontal mounting surface.
- Install the machine only on a stable foundation, and anchor it securely.
- Arrange for an adequate working height

Machine mounting:

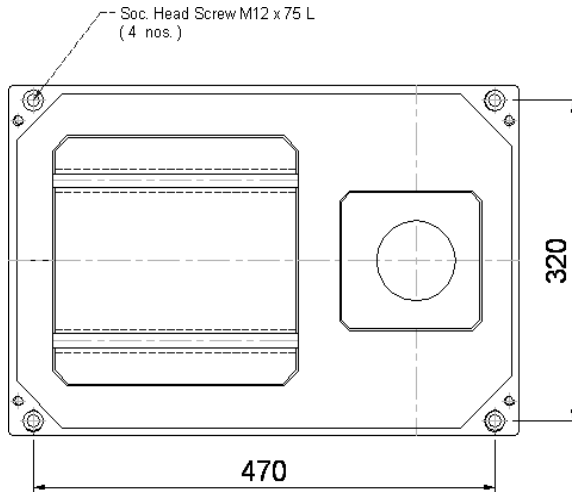

- mark and drill & anchor for M12 screws on the concrete ground
- Drill pattern for machine as per model.
- Use two spring washers for each screw.
- Compensate for floor unevenness with sheet steel.
- Do not bend sub- structure.
- If you use insulating boards, it will add for noise reduction & oscillation damping.

Tool holding:

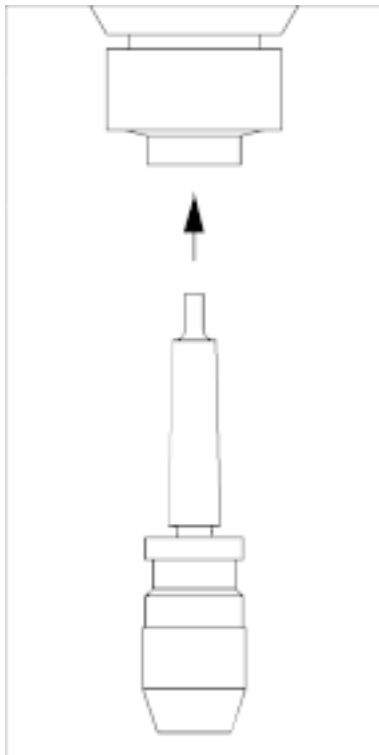

- Insert drill chuck with easy jerk
- Test fixed fit
- MT-2 Taper for DB/DC-23A
- MT-3 Taper for DB/DC-28A

Speed Chart

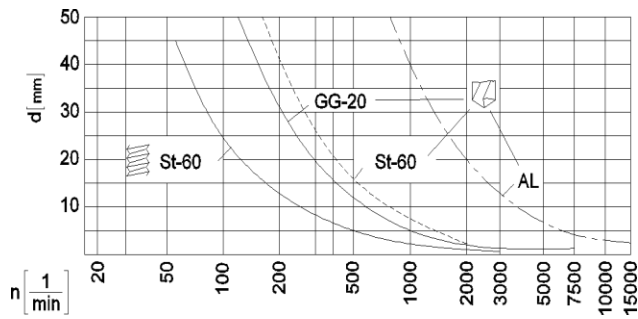

- Adjust the rotating speed of spindle according to material of work piece and drill size
- Speed is in RPM

ELECTRICAL INSTALLATION

- Make sure Incoming Supply is three Phase supply 415VAC Proper.
- R, Y, B connection is connected as per sequence.
- Neutral and earth is compulsory.
- Insure the panel box is away from the water Leakage.

Note:

- Do not touch live wire with hand.
- For installation use Tester and Hand Gloves.

POWER – UP:

INSTALLATION

After installation and checking all above check points, machine can be powered up for checking basic machine operations. Switch on the incoming electrical power isolator.

- Check if machine lamp is working ok. (Via. Lamp ON/OFF switch on from panel box.)
- Start machine motor via. Start signal of motor ON switch.

CHECK DIRECTION OF SPINDLE ROTATION!

- Spindle to run clockwise when viewed from operator position.
- {Inter – change any two in – coming phase lines, if direction needs to be changed.}

[IF – IN – DOUBT]

Please contact M/S Ahire Machine Tools PVT. Ltd. personnel and / or its authorized representative in your Area. Commissioning at site [by M/S Ahire Machine Tools PVT. Ltd. personnel can be provided at extra cost.](#)
(If required.)



Manual of POWER FEEDER machine

INDEX

1. Control panel
2. HMI Screen and User Input/Programming
3. Precautions.

1. CONTROL PANEL

POWER FEEDER unit is powered and controlled by components fitted in control panel box. There are two switches & two led lights on front side of panel functioning described as below-

Red switch - ON/OFF

Black switch - for Manual & Auto mode Red

Light - Auto mode is ON

Green light - Manual mode is ON

2. HMI Screen

A. HOME

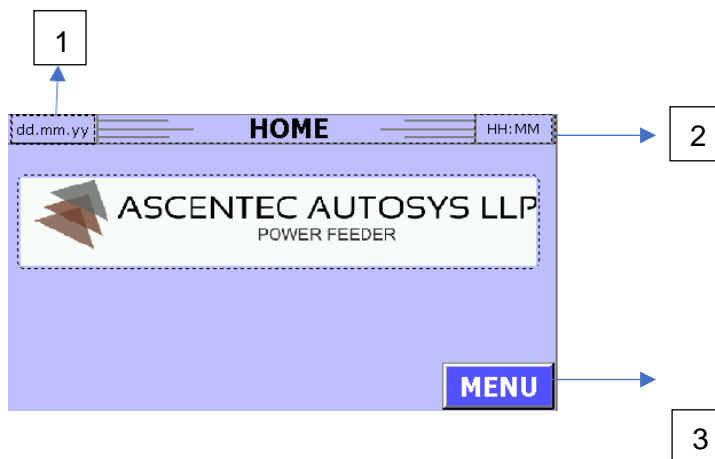

1. Date (dd.mm.yy)
2. Time (24 hr)
3. Menu button

B. MENU

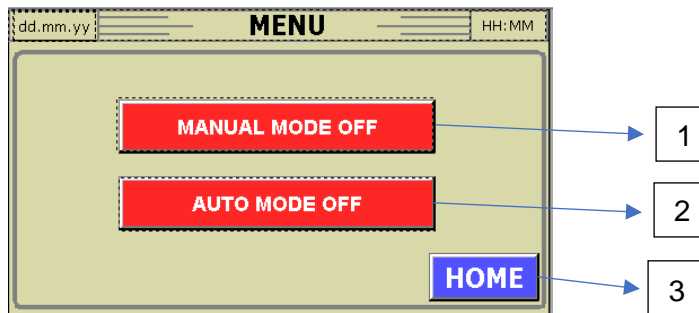

1. MANUAL MODE- Click for manual mode for setting spindle up-down direction.
2. AUTO MODE- Click for automatic mode.
3. Home button- Click home button to go back to main menu.

C. Manual Mode

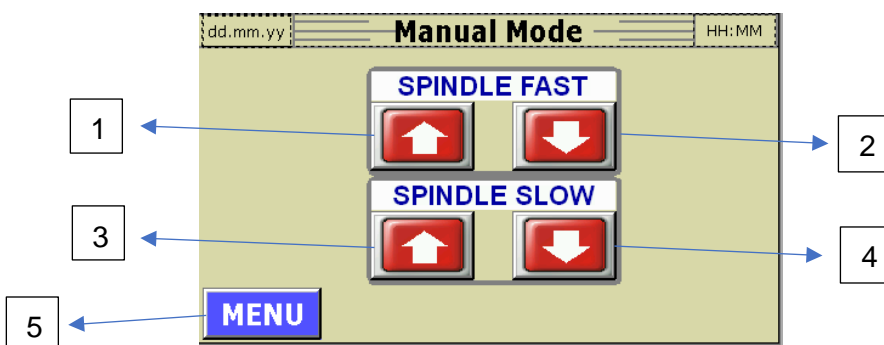

Number 1,2,3,4 to move the spindle up or down manually with required speed.

D. Auto Mode

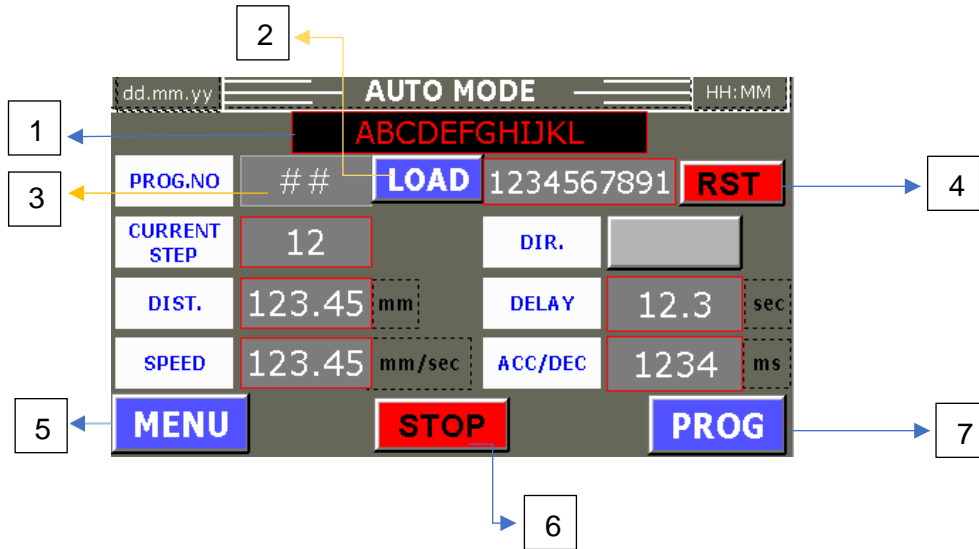

1. Shows name of the program.
2. Load desired program.
3. Change/selection of the program.
4. Reset cycle counter to zero.
5. Go back to Menu
6. To stop the cycle and set the spindle at start/home position.
7. Program list.

E. Program List

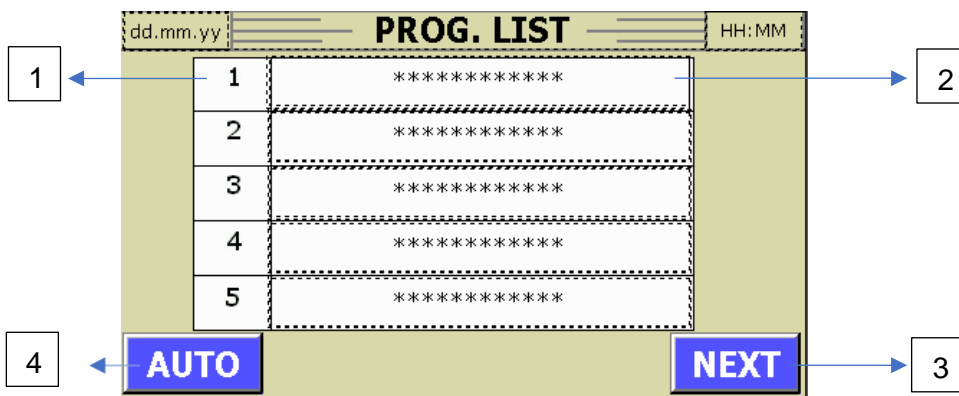

1. No of program
2. Shows name of program and can input/edit program
3. Next program list
4. Auto mode

F. Program

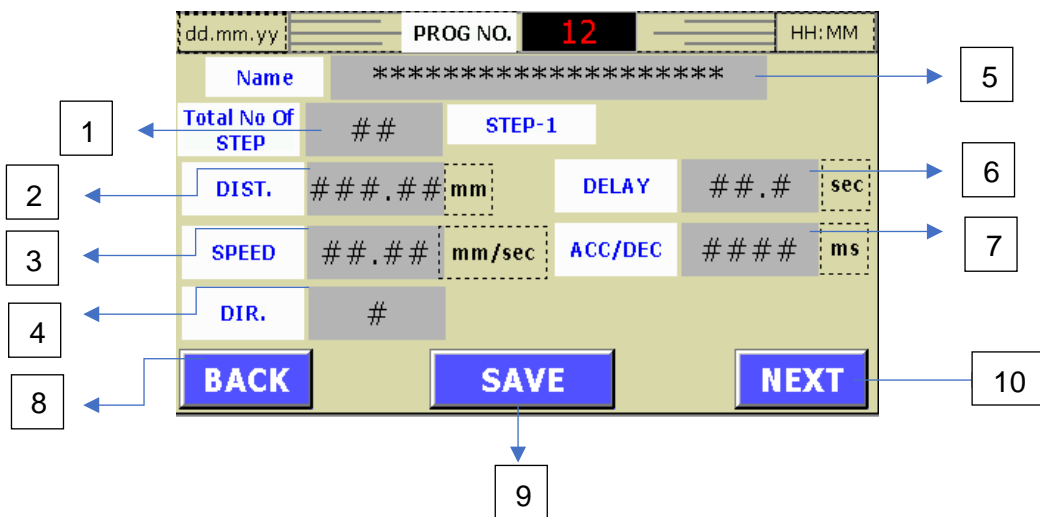

1. Total number of steps is number of movements of spindle that will run on Auto mode.
2. Distance travel of spindle (L.C. 0.01mm)
3. Speed of Spindle (mm per second)
4. Up & Down direction of Spindle (1 for Down & 2 for Up)
5. Type the name of program
6. Delay time to stop the spindle after current step (in Second)
7. Acceleration & deacceleration of spindle speed (in micro second)
8. Go back to Program List.
9. To save the program.



10. Next step

3. Precautions:

1. Do not load any type of material on control panel box.
2. Control panel box, screen, motor & push button box should be oil & water free. It should be clean & dry.
3. Make sure that spindle is freely moving up & down direction.
4. Make sure that all electrical wiring is unstretched

CHECK LIST FOR START-UP

After successful erection of DB/DC-23/28A machine and necessary provision of electrical power connections, following points MUST be ensured for initial START – UP of machine.

No	Description	Area	Check mark
1	Leveling of machine completed and leveling screw locked	General	
2	All necessary machine parts cleaned and oiled	General	
3	Work table / head stock moved to normal position (If required)	General	
4	Safety rings / head stock / work table clamped on column	General	
5	Electrical input connected to machine through isolator and checked ok	General	
6	Earthing connection provided to machine / panel checked ok	General	
7	All machine wiring checked for any damage and rectified (if any)	General	
8	R/Y/B/N connections to junction box checked and sequenced ok	General	
9	Tool holder and tool REMOVED from spindle. (if applicable)	General	
10	Top cover / front safety guarding position(if applicable)	General	
11	Belt tension checked ok manual movement of spindle ok	General	

Please note, above check list points are given as starting reference. This list is NOT a full / final list and many routine checks as per individual customer policy and statutory requirements may be necessary to follow, during initial start – up for machine.

OPERATION

MOUNT/REMOVING TOOLING

	<ul style="list-style-type: none"> * Switch-Off power supply & ensure spindle has stopped * Clean hands, Use cotton cloth for cleaning parts. * Take necessary care during removal & risk of tool
---	--

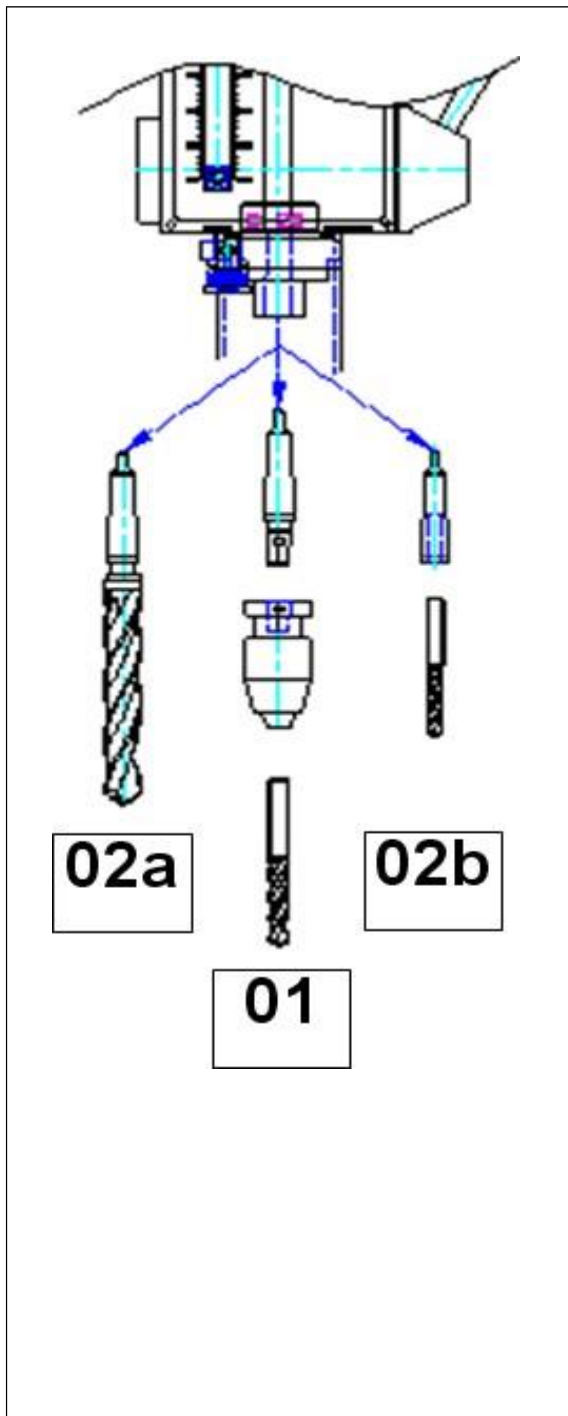

Mounting straight shank tools

- Straight shank tools (Drill/Reamers/Spot facing) can be mounted in spindle using drill chuck, collet chuck and MT-2 shank arbor.
- Clean spindle nose (MT-2 taper bore) / tool holder.
- Select correct size tool holder and arbor.
- Fix arbor and tool holder together. (Taper fixing)
- Mount arbor + tool holder assembly into spindle by firmly pushing arbor against spindle in one quick action. (Ensure correct tang orientation of arbor).
- Check true running of mounted tool holder.
- Insert tool shank and firmly grip it in chuck.
- CHECK TRUE RUNNING TOOL BEFORE USE.

Mounting taper shank tools

- Tools with MT-2 taper can be mounted directly into spindle nose.
- For tools with MT-1 taper, suitable MT-2 to MT-1 reduction sleeve is necessary.
- Clean spindle nose (MT-2 taper bore) / tool holder.
- Select correct size tool and sleeve (if required)
- Fix sleeve & tool together. (Taper fixing if required)
- Mount tool assembly into spindle by firmly pushing MT-2 taper portion against spindle in one quick action. (Ensure correct tang orientation)
- CHECK TRUE RUNNING OF TOOL BEFOR USE.

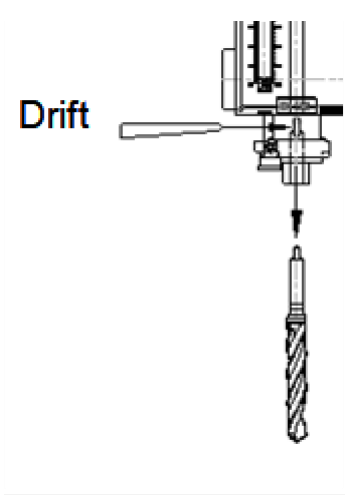
 <p>Drift</p>	<p>Removal of tools/ holders from spindle</p> <ul style="list-style-type: none"> • Tools / holders mounted into machine spindle can be removed easily using a taper drift / wedge. (Supplied with machine). • STOP SPINDLE AND SWITCH - OFF SUPPLY • Lower spindle and insert it from small drift slot with sleeve drift slot. • Use provided drift / wedge and insert it from small side into drift slots (of sleeve & spindle) • Lightly hammer / tap open end of drift to drive it into slot, to cause tool / arbor to slip-out from taper holding. • USE GLOVES TO PROTECT HANDS
--	---

⚠ WARNING

- * **NEVER ATTEMPT** removing tool / arbor etc. by moving spindle / sleeve against head stock, while drift / wedge is in slot. This will damage sleeve / drift / spindle.
- * **Take care!** Tool / Arbor/ Chuck etc. may slip – out during mounting / removal and may cause injury.
- * **Take care!** While lowering head stock / work table, safety ring must be positioned + locked in desired position, before loosening head- stock / work table on column.
- * **Take care!** When changing tools, installing pulley belt, Changing speeds.

ADJUST DISTANCE BETWEEN DRILLING BIT AND WORK PIECE

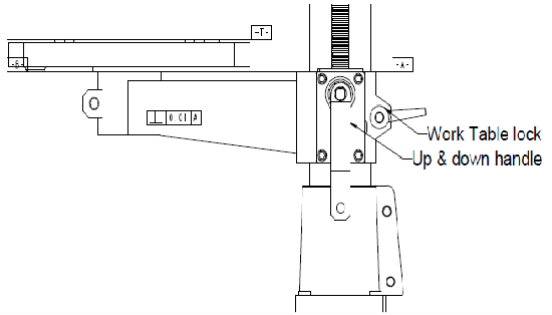
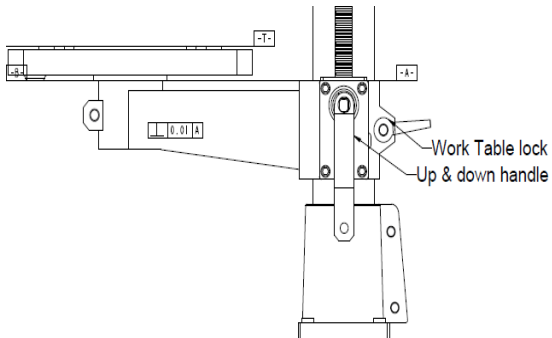
 <p>Work Table lock Up & down handle</p>	<p>Tool & Work piece distance adjust</p> <ul style="list-style-type: none"> By using work table clamp handle rotate CW/CCW direction for UP&DOWN moment, and according to work adjust the distance.
<p>Moving work table UP/DOWN</p>  <p>Work Table lock Up & down handle</p>	<ul style="list-style-type: none"> Work table is mounted on seamless column and can be moved UP/DOWN on column, quickly as desired, by simple action. Ensure that work – table is clamped on column Loosen work – table clamp handle slowly and allow work table to lower itself by gravity. Re – tighten the clamp bushes for work – table to firmly lock its position. <p>Work table – rack & pinion UP / Down</p> <ul style="list-style-type: none"> Optionally, machine may have rack and pinion system for moving work table. In such case, safety rings are not required. Up/ down action is by operating handle

TYPES OF OPERATION

DB-23/28A machines are general purpose machine, which can be used for number of machining operations, with the help of suitable tools and tool holders.

Specific recommended spindle speed should be selected, as per operation and controlled manual feeding should be employed for consistent results.

Various machining operations generally done on machine are...

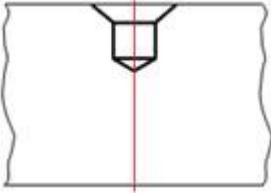
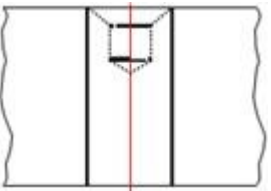
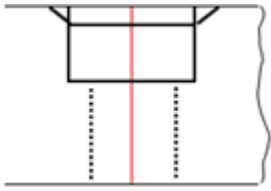
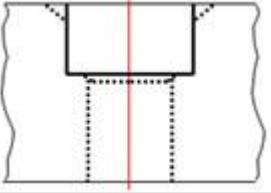
Various machining operations generally done on machine are...		
1	Centering / Center Drilling	
	To generate a starting point or guide reference at desired on component, for drilling operation.	
2	Drilling	
	To generate a specific size hole in component. Drilled hole can be "Through" or "Blind", as per component requirement. Set drill depth correctly for blind holes.	
3	Chamfering / C'sinking / C'boring	
	Chamfering / C'sinking is generally done to provide smooth edge, remove burr from hole entry / exit. Counter- boring is generally enlargement of hole, by suitable End-Milling cutter. (at low feed)	
4	Reaming	
	Reaming is used to make accurate size, smooth finish holes, using HSS / Carbide machine reamers. Pre- drilling / End milling operation is necessary before reaming, keeping about 0.2 - 0.3 mm allowance.	

Please note, generally machining applications have been listed above. Take care! Observe all necessary safety pre - cautions during machine operation.

Machine is not intended for FACE MILLING / HEAVY PLUNGE CUTTING operations.

Unless otherwise specified, floating tap chuck with length compensation should be used for tapping operations.

* **DO NOT OVERLOAD MACHINE. FOLLOW NORMAL GOOD MACHINING PRACTICE**



MAINTENANCE SCHEDULE

M/S AMT recommend following schedule guide for maintenance of Auto feed machines. This should be considered during normal use and maintenance of machine.

No	ACTIVITY DESCRIPTION	TYPE	FREQ.
1	Cleaning chips / coolant remains from table / Fixture of M/C.	General	Daily
2	Checking that tool holders / tools are mounted firmly.	General	Always.
3	Visual check for oil leakage from spindle oil seals	General	Daily
4	Providing lubrication to spindle – sleeve / splines / Pinion etc.	General	Daily
5	Checking / adjusting spindle – motor pulley belt tension	Mech.	Bi – weekly
6	Checking spindle run – out / tracking accuracy	Mech.	Yearly
7	Replacement of defective / worn – out parts	Mech.	As required
8			
9			
10			

GENERAL USE / MAINTENANCE:

DB/DC-23/28A (Autofeed) machine is modern machine, involving mechanical / electro – mechanical / electrical etc. sub – systems. To keep machine fully productive over prolonged period, It is essential to carry out normal scheduled maintenance activity to check and rectify (whenever required) these sub – systems.

Following points should be noted as general guidelines for machine use/ maintenance.	
1	Clean the machine at the end of day and apply oil/ Grease at specified points.
2	Observe all safety conditions, without any deviations.
3	Never overload machine or temper it with rough handling.
4	Ensure proper belt tension.
5	Provide necessary lubrication oil/ grease, at suitable interval, as required
6	Always clean the tool holder / tool / spindle nose etc. during tool change.
7	Keep protective guards "in position" during machine operations.(if applicable)

8	Ensure clean /stabilized 415v,3ϕ, 50Hz incoming supply.
9	Establish tool changing frequency and replace dull tools immediately.
10	Replace worn – out parts promptly.(Use quality standard purchase items)
11	Inspect oil leakage from oils seals / O – rings periodically (Change defective seals)
12	Check spindle run – out and other alignment accuracy periodically.
13	Observe any abnormal noise during machine operation / maintenance
14	Always follow the maintenance schedule. (Mechanical /Electronic / Electrical)

⚠ CAUTION

Keeping / maintaining machine in fully working condition is joint responsibility of production and maintenance personnel. Ensure that all the concerned personnel are trained in normal use and subsequent maintenance activities of the machine.

M/S AHIRE MACHINE TOOLS Pvt. LTD. Welcomes you for any kind of suggestions from our valued customer, regarding any improvements / betterment of machine sub – system / functioning, in operation and / or maintenance and / or safety.



LUBRICATION:

Provide clean, fresh lubrication oil (light grade) to specific machine mating parts / surfaces. Provide periodic grease lubrication for back – gear arrangement.

Avoid belt – pulley area getting contaminated with grease / oil drops etc.

No.	Area	Lub.	Freq.
1	Spindle spline area	Sliding oil	Daily
2	Spindle sleeve / Quill	Sliding oil	Daily
3	Work table top face	Sliding oil	Daily
4	Base plate top face	Klüberpaste	Daily
5	Work table guide	Klüberpaste	Weekly
6	Socket guide	Sliding oil	Weekly
7	Gear Changing Knob.	Sliding oil	Weekly

Area Equivalent lubrication brands	
1..6	BP= Hydro 22, Castrol = Hyspin 22, IOC = Servo spin 22
7	BP = Unkivex - A, Castrol = All-purpose grease, IOC = Servo gear MP

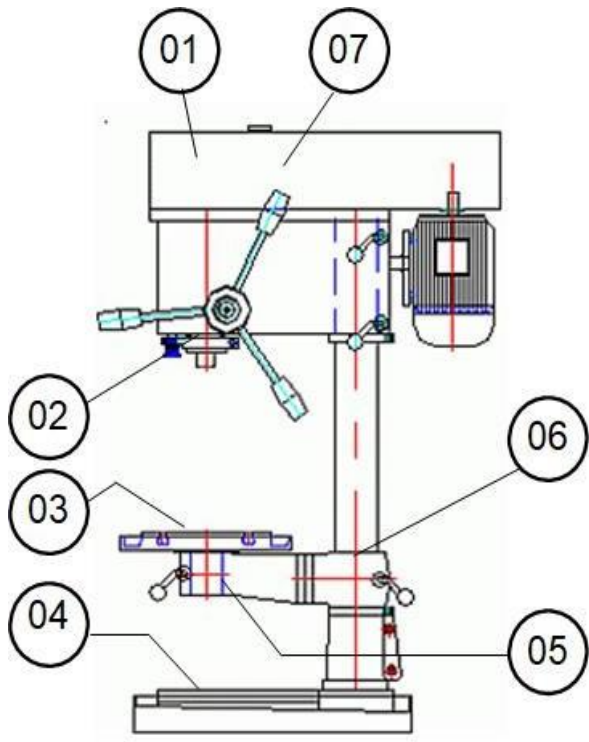

The diagram shows a vertical machine structure with various components. Callout 01 points to the top housing. Callout 02 points to a gear mechanism. Callout 03 points to a horizontal guide surface. Callout 04 points to a lower guide surface. Callout 05 points to a base component. Callout 06 points to a motor or drive unit. Callout 07 points to a top adjustment knob or gear.

Lubrication is done with just few oil drops (5 – 10 nos.) at – a – time, at each point.

Ensure that OVER-LUBRICATION is NOT done. This will otherwise mess the machine / internals.

Lubrication and maintenance schedules are as guide – lines only.

Activities MUST be scheduled, as per required / established frequency, to maintain desired accuracy.

BELT REPLACES:

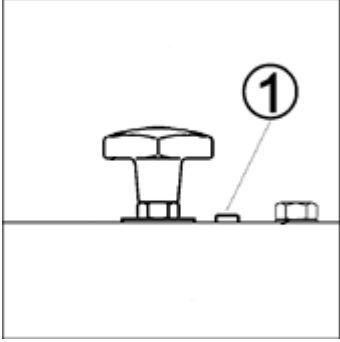
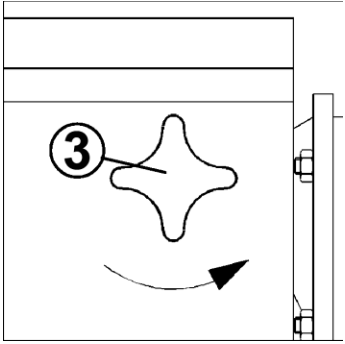
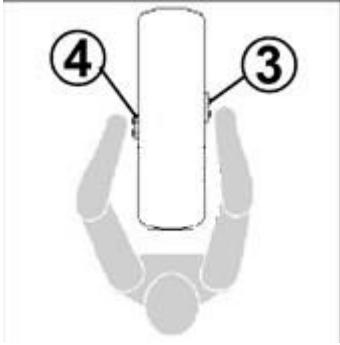
	<ul style="list-style-type: none"> • First confirm the MCB off. • The machine is equipped with an AMT protection cover saving • Notice backlash of drilling spindle • Only open protection cover when drilling spindle is completely in standstill • Visual check • Loose fastening screws (1) and pull protection cover up.
	<ul style="list-style-type: none"> • Top cover places a side. And • Loose right start grip screw 3 • Turn left star grip screw 4 until belt is not fixed • Now remove the belt and replace it with new belt • Belt Size is (A 48).
	<ul style="list-style-type: none"> • Put new belt in desired position • Tension belt (left star grip screw 4) • Maintain tension • Set star grip screw on right hand side tight • Place protection cover as like previously. • Set fastening screws (1) tight

TROUBLE SHOOTING

Malfunction Table:

NO	PROBLEM / FAULT	POSSIBLE CAUSE/S	SOLUTION
1	Machine does not start	<ul style="list-style-type: none"> • Power supply off • Single phasing • Blown fuse or MCB trip • Input supply cable damaged 	<ul style="list-style-type: none"> • Check incoming power supply main's ON/OFF switch, Electric panel, control panel. • Check cable / connections.
2	Main's power "on" but machine does not start	<ul style="list-style-type: none"> • MPCB / MCB tripped or off • Motor cable connections loose / open / faulty. • Motor winding damage 	<ul style="list-style-type: none"> • Check MCB tripping & reset • Check motor connections (rectify / rewire as required) • Check motor operation / wiring
3	Spindle rotates but, NOT at desired speed.	<ul style="list-style-type: none"> • Belt tension not correct • Pulley setting incorrect 	<ul style="list-style-type: none"> • Check and set belt tension. • Correct the pulley setting.
4	Spindle speed ok, but machining cannot be done. (or tool brakes without cutting)	<ul style="list-style-type: none"> • Check direction of rotation for spindle / tool. • Tool dull / worn – out / Broken 	<ul style="list-style-type: none"> • Rh tools need, spindle rotation CCW, when viewed by operator. • Check and 0 correct, if required. • Check tool condition & rectify
5	Spindle / sleeve retract very fast. [or] Spindle moves down, when at rest / retracted position.	<ul style="list-style-type: none"> • Retract spring tension high • Retract spring tension low 	<ul style="list-style-type: none"> • Adjust spring tension as per load and stroke. • Adjust spring tension as per load and stroke.
6	Rattling noise during machine operation. (mainly at high speeds)	<ul style="list-style-type: none"> • Worn – out / Damaged bearing 	<ul style="list-style-type: none"> • Check and replace bearing



7	Coolant flow stopped	<ul style="list-style-type: none"> • Coolant pump not started or not 	<ul style="list-style-type: none"> • Check coolant pump supply, MCB
		operating. <ul style="list-style-type: none"> • Pump rotating in reverse. • Shut – off valve closed • Plug not connected 	/ Overload relay etc. <ul style="list-style-type: none"> • Correct pump rotation • Check / open shut – off valve. • Check plugs connection.
8	Actual coolant flow starts late (after some delay). (Delay of 3 – 5 sec. May be normal, due to piping length.)	<ul style="list-style-type: none"> • Extra – long piping • Less coolant in tank • Pipe chock – up 	<ul style="list-style-type: none"> • Reduce pipe length if possible • Refill coolant up to max. level • Clean piping / nozzles • Check / clean pump inlet port.

Note:

- Refer above data table to identify problem / cause and take appropriate action.
- Ensure to follow all necessary SAFETY procedures while doing maintenance work.
- Maintenance MUST be done by trained personnel or under supervision of such personnel.
- In case of any doubt and / or assistance required, contact M/s AHIRE MACHINE TOOLS., NASHIK.
- For any other operational problem not listed in above table, report immediately to... M/s AHIRE MACHINE TOOLS, NASHIK. And / or its local representative.

REPLACEMENT OF PARTS

Disconnect power supply, before doing maintenance work. ! ASK IF – IN –DOUBT!

Refer table showing for estimated / expected working life of major wearing parts of machine. Working / Service life figures indicated are based on theoretical calculation (one shift usage).

S. No.	Part name	Qty.	Estimated life
A	Spindle and Drive shaft assembly		
1	Spindle shaft	1no.	2 years or 5,000 hrs.
2	Spindle drive shaft	1no.	2 years or 5,000 hrs.
3	Spindle bearings (set of 2 bearings)	1no.	2 years or 5,000 hrs.
4	Drive shaft bearings (set of 2 bearings)	1no.	2 years or 5,000 hrs.
5	Spindle pulley with bush	1no.	2 years or 5,000 hrs.
B	Pinion shaft arrangement		
1	Pinion shaft	1no.	3 years or 7,500 hrs.
2	Bearing for pinion shaft	1no.	2 years or 5,000 hrs.
3	Bush for pinion shaft	1no.	2 years or 5,000 hrs.

- * **USE ORIGINAL M/S AMT SPARE-PARTS** for machine and reputed make / good quality- standard purchase items during maintenance.
- * Ensure logical, systematic disassembly and re – assembly.
- * It is recommended to replace complete set of bearings in spindle / driveshaft.
- * Overloading, abusing, mishandling and / or improper maintenance will not only reduce working life of parts considerably, but may also damage the consistency inaccuracy of machining.

Please note, above figures are only given as general guide – lines. Actual working life of parts depends on various factors and will be different for each part on each machine.

- * Observing good machining / house – keeping practices.
- * Maintaining a successful maintenance schedule.
- * Providing correct daily lubrication.
- * Training operators in machine usage and care etc.
Will extend working life of all parts (and machine).

List of items shown above are indicative and does not imply that only these parts are required as spare

SCHEMATIC HEAD – STOCK ASSEMBLY

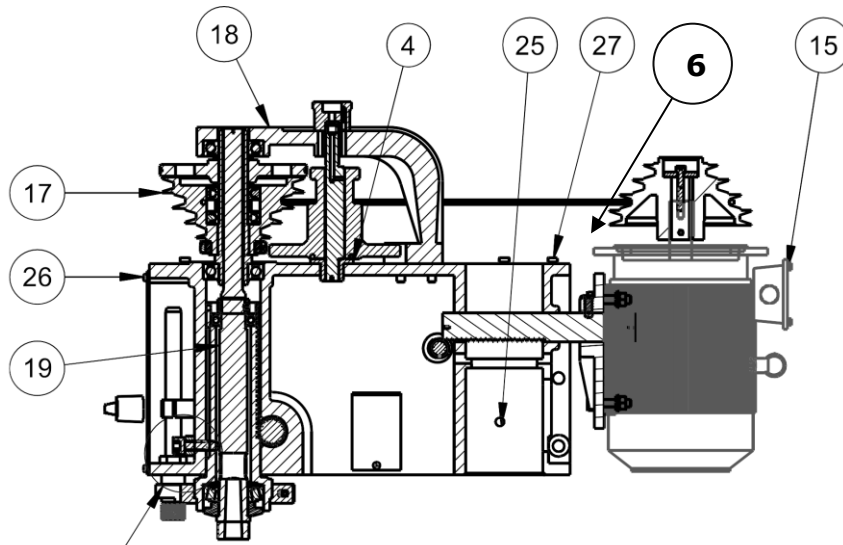

SEE DETAIL A

WORK TABLE ASSEMBLY

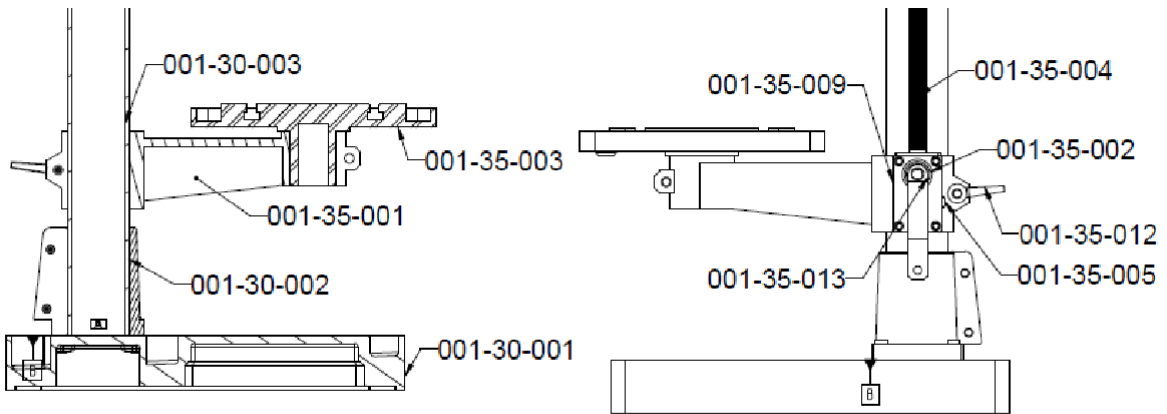

NOTES:

- 1) Refer schematic head stock sub assembly (For more details).
- 2) Machine base within – built coolant tank arrangement is optional (against order).
- 3) Rack – pinion system for head stock or work table UP/DOWN movement, is optional.
- 4) Refer page no. – For replacement of par

ELECTRICAL CIRCUIT DIAGRAM

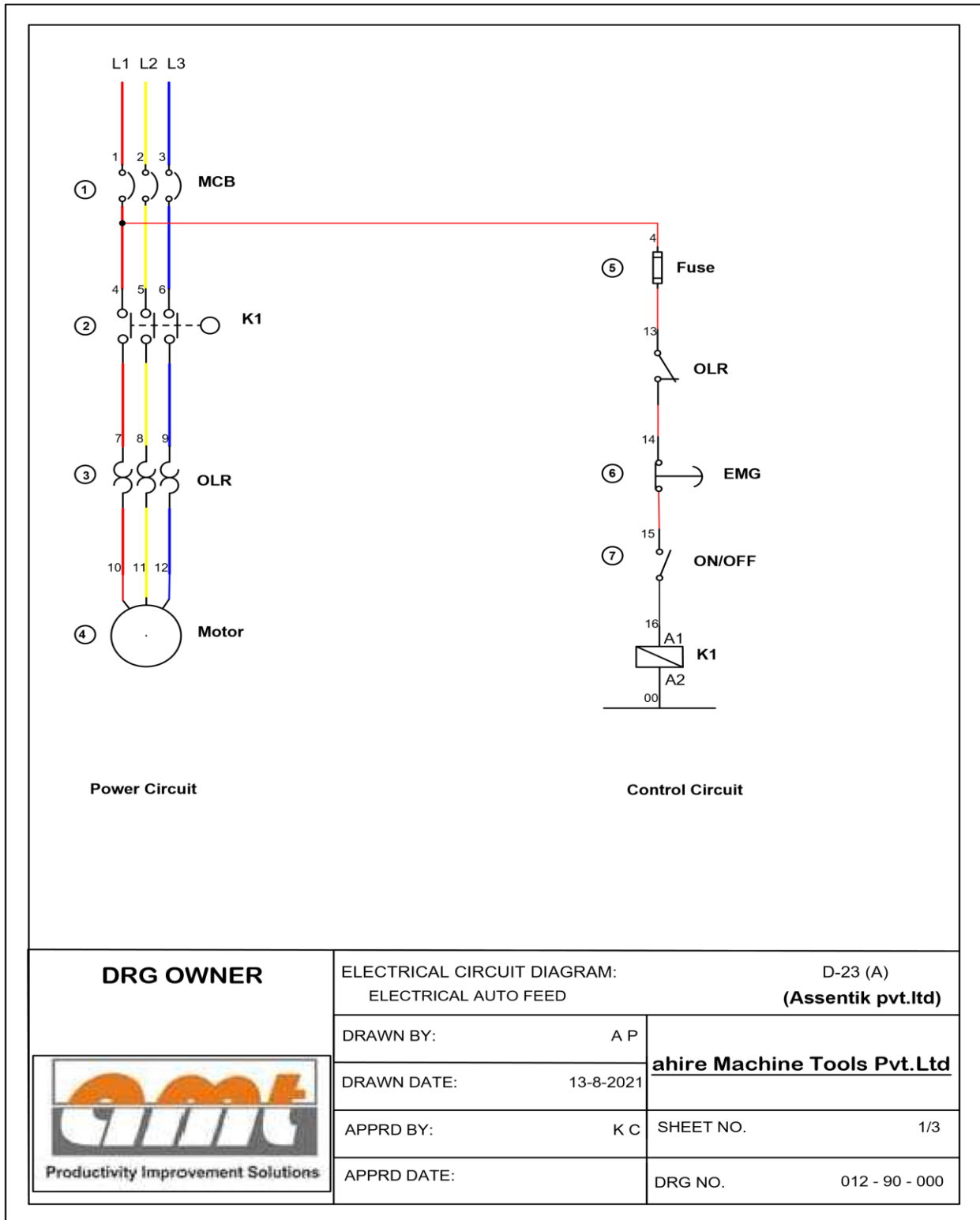

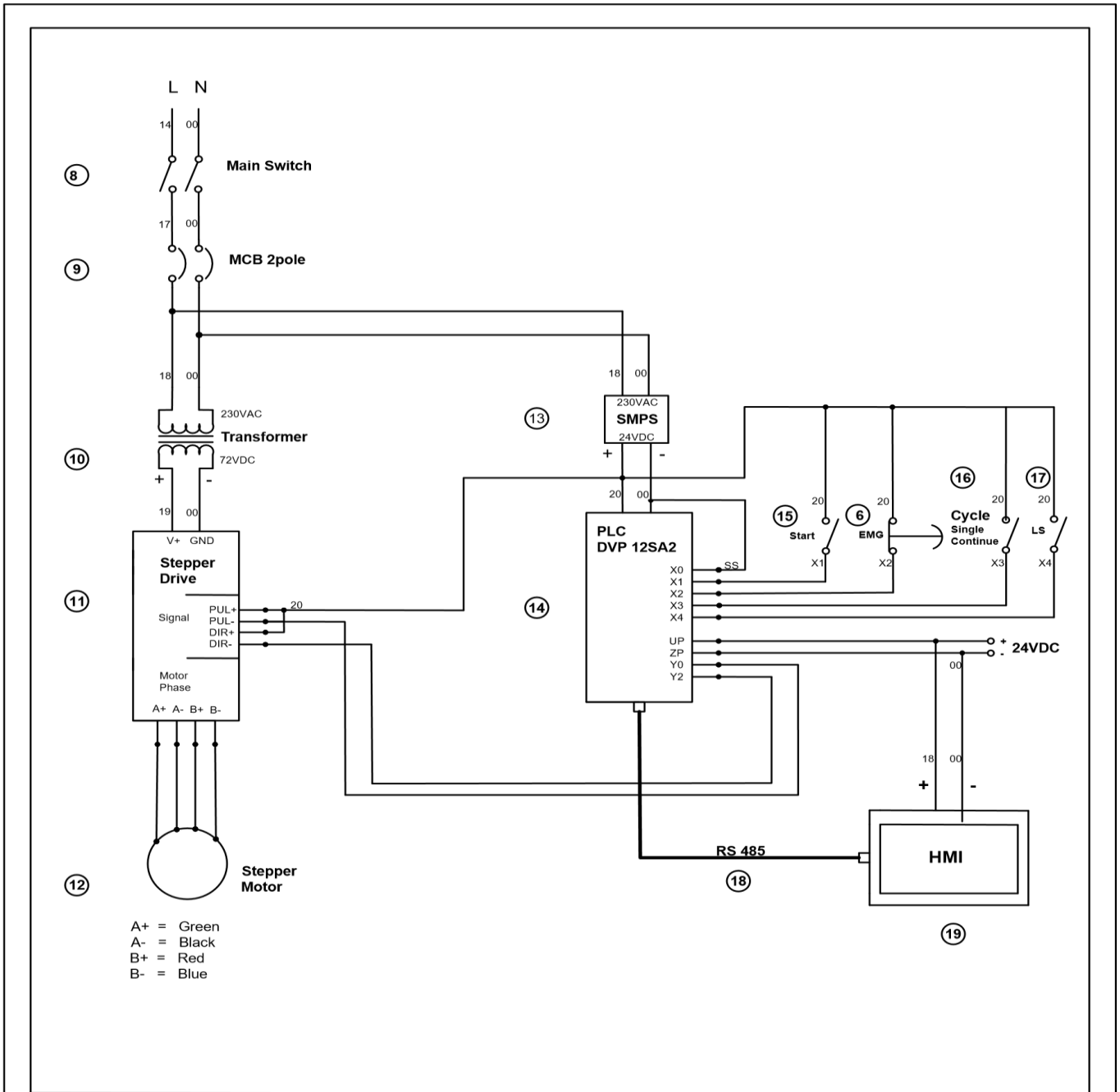

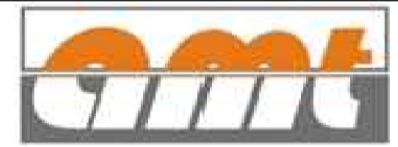
DRG OWNER  Productivity Improvement Solutions	ELECTRICAL CIRCUIT DESIGN: D-23(A) ELECTRICAL AUTO FEED (Assentik pvt.ltd)	
	DRAWN BY: A P DRAWN DATE: 16-8-2021	ahire Machine Tools Pvt.Ltd
APPRD BY: K C APPRD DATE:	SHEET NO. 2/3	DRG NO. 012-90-000

